

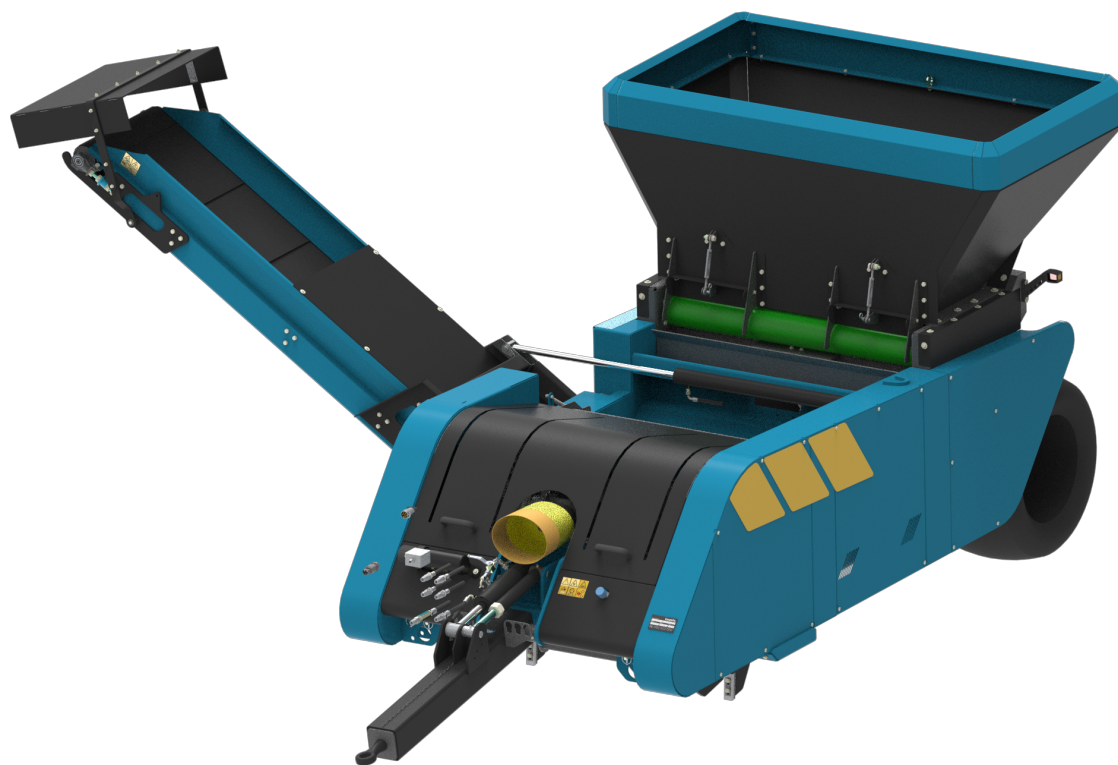

TopDrain
1000
Manual



Copyright © **Imants® BV** 2023

Imants® BV reserves the right to alter parts at any desired moment, without prior or direct notification to the purchaser.

The contents of this document may equally be amended without prior warning.

For information about settings, maintenance work or repair that this document does not cover, you are recommended to contact your supplier's service department.

Great care has been put into compiling this document. **Imants® BV** cannot, however, be held responsible for any errors it may contain or any consequences they may have.

All rights reserved. Nothing in this document may be duplicated, stored in an automated database, or made public, in any form or way, whether electronic, mechanical, by photocopying, recording or in any other way, without prior written permission from **Imants® BV**. This also applies to the associated drawings and diagrams.

Table of contents

1 Foreword	7
2 Safety instructions	8
2.1 Explanation of pictograms.....	8
2.1.1 Hazard indications.....	8
2.1.2 Meanings of pictograms.....	9
2.1.3 Meanings of operating pictograms.....	10
2.2 General safety instructions.....	11
2.3 Warning stickers on the machine.....	13
2.4 Position of the warning stickers and type plate on the machine.....	15
2.5 Operator's responsibilities.....	16
3 Residual risks	17
4 General description of machine	18
5 Machine specifications	20
5.1 TD1000.....	20
6 Loading and unloading the machine	21
7 Putting the machine into operation	22
7.1 Putting the PTO shaft into operation.....	23
8 Transport	24
9 Working with the machine	25
9.1 Tractor settings.....	26
9.2 Coupling the machine.....	27
9.3 Machine settings.....	28
9.3.1 TopDrain operation.....	28
9.3.2 Adjustable drawbar.....	29
9.3.3 Wheel set.....	30
9.3.4 Sand supply system.....	31
9.4 Starting and stopping work and settings.....	32
9.5 Blocking the machine.....	34
9.6 Uncoupling the machine.....	35
10 Maintenance of the machine	36
10.1 Daily inspection.....	37
10.2 Drive train.....	38
10.2.1 PTO drive shaft.....	38
10.2.2 Gear box.....	39
10.2.2.1 Middle gearbox.....	40

10.2.3 Hydraulic system.....	41
10.2.4 Tension the chain.....	43
10.2.5 Tensioning the V-belt.....	45
10.3 Periodic maintenance and inspection: Lubrication of machine Checking the vent nipples.....	46
10.4 Conveyor belts.....	47
10.4.1 Tensioning: general information.....	47
10.4.2 Tensioning the supply conveyor.....	48
10.4.3 Tensioning the lateral conveyor.....	48
10.4.4 Tensioning the sanding belt.....	49
10.5 Wear parts.....	50
10.5.1 Replace TD Chisel.....	50
10.5.2 Replace TD Sand supply sand scoop.....	52
11 Cleaning.....	53
12 Decommissioning.....	54
13 Warranty.....	55
14 Appendix/Appendices.....	56
14.1 TD100 hydraulic diagram.....	56
14.2 Electrical layout of 7-pin plug.....	57
14.3 Electrical layout for vibration motor.....	58
15 CE declaration.....	59

1 Foreword

First of all, we would like to congratulate you on purchasing a **Imants®** machine. You have chosen a high-quality product. If used correctly, your machine will bring you many years of enjoyment.

This Manual is an important document to ensure the machine is used correctly. It contains all the information required to use the machine safely and optimally.

We recommend that you read this Manual thoroughly and that you study and follow all the instructions before using the machine for the first time. The illustrations used in this Manual may differ from the configuration of your machine; they are merely intended to explain a working principle.

Please contact your point of sale/dealer should there be any questions or ambiguities as regards this Manual.

We update our manuals regularly. Your suggestions help us to make our manuals even more user friendly. You can e-mail your suggestions to info@imants.nl with 'manuals' in the subject line.

Imants® BV accepts no responsibility whatsoever for any damage or consequential damage due to the incorrect use of the machine.

For this Manual, it is a "Original document".

2 Safety instructions

The machine has been carefully designed and professionally built to allow it to be worked with safely. The CE Declaration confirms this. There are always however hazards and safety risks that cannot be excluded. The functions of the machine and its operation by the operator give rise to these hazards and risks.

This chapter covers the safety instructions and precautions, how these are brought to your attention and with which the operator must comply. It is extremely important that you are properly familiar with the safety instructions and rules and that you respect them in all circumstances!

2.1 Explanation of pictograms

Pictograms are present under many headings in this manual. Symbols have also been applied to the machine. In this chapter, you can see what these pictograms and symbols mean, what they refer to, or what they are warning you about.

2.1.1 Hazard indications

The symbols below indicate a possible danger of personal injury. The symbol is composed of an equilateral triangle surrounding an exclamation mark.

Warning pictograms that are used in the Manual but are not present on the machine as stickers.



Warns of hazardous situations which must be avoided absolutely and are likely to result in death or serious injury.



Warns of a hazardous situation that, if not avoided, could lead to death or serious injury.



Warns of a hazardous situation that, if not avoided, could lead to slight or more significant injury.

This symbol is not a hazard symbol but rather an information symbol.



Provides additional information aimed at facilitating or improving the use of the machine.

2.1.2 Meanings of pictograms























Below, you can see what the illustrations in the manual mean, what they refer to, or what they are warning you about.

	Danger of personal injury		Fire hazard
	Hot surfaces		Trapping risk
	Moving parts		Leakage
	Explosive substances		Safety footwear
	Hearing protection		Gloves
	Eye protection		Clothing stipulations
	Document reference		Use of tools
	Material use		Read the manual
	Danger of becoming trapped due to being present within the lifting range		Danger of becoming trapped due to the machine lowering unintentionally
	Danger from hydraulic oil under high pressure as a result of leaking hydraulic hoses!		Max. hydraulic system pressure
	Unintentional starting and rolling away of the machine		Recycle
	Acceptable, correct		Unacceptable, wrong
	Use lifting hook		Visual inspection

2.1.3 Meanings of operating pictograms

Operating pictograms indicate schematically what action must be taken or what setting must be chosen.

The summary below includes all possible pictograms, which does not mean they are all used in this Manual:

	On		Off
	Hitch tension adjustment		Hitch position adjustment
	Hitch downwards		Hitch upwards
	Hitch working depth		Pressure gauge
	PTO on		PTO off
	PTO 1000 rpm		PTO 540 rpm
	Front wheel drive		Direction of travel
	Engage gear		Engine speed down
	Engine speed up		Ram in floating position
	Ram in		Ram out
	Fold out		Fold in

2.2 General safety instructions



The user must hold a valid tractor driving licence in order to operate the machine.



The user must be at least 16 years old, unless the local legislation stipulates a higher minimum age. The higher age limit shall prevail.



The user of the machine is responsible at all times for compliance with local safety regulations and guidelines.



The user must have read through the whole contents of this manual and must follow to the letter the instructions therein.



Keep this manual and that of the PTO drive shaft within reach.



Use the machine solely for the purpose it was designed for.



The machine may only be used and maintained by persons who are familiar with the machine and have been made aware of the risks. No-one who could not be expected to make correct use of the machine is to be permitted to commission or operate the machine.



All safety facilities must be assembled on to the machine and be in good conditions. Never remove or open a guard when the machine is running.



Always follow the specifications and requirements set by the manufacturer of the tractor in relation to its use. Please refer to Tractor manual.



Always comply with the requirements regarding the maximum load of the front and rear axles, given by the tractor manufacturer.



Standing on or within the range of the machine during work is prohibited. This also applies during transport.



The maximum load of the tractor tyres, given by the tyre manufacturer, should not be exceeded during operation of the machine.



Warning labels should always be legible.



Work may only be carried out under a raised machine if the machine has been properly supported.



For reasons of quality and safety, only use original **Imants®** parts.



Maintain the machine as indicated later in the manual. Only perform this work when the machine is at a complete stop. Remove the key from the tractor's ignition.



Modifications, additions or developments on or to the machine are not allowed without the written permission of Imants BV. This includes welding on load bearing parts. Without this written authorisation, Imants BV's responsibility for the CE marking is invalidated and is passed on to the buyer.

2.3 Warning stickers on the machine



See [Position of the warning stickers and type plate on the machine](#) on page 15 for the position of the warning stickers.

The warning stickers below can be found on the machine.



Crushing hazard. Keep hands and fingers away from the exposed, moving parts of the machine!

It could cause serious physical injury with the possible loss of a hand or an arm.

Keep your hands and arms away from the hazardous area while the tractor engine is running and the PTO drive shaft and/or hydraulic system are connected.



Danger of hand or arm being pulled in or gripped by a powered and unprotected chain or belt drive.

This hazard can cause serious physical injury with the possible loss of a hand or an arm.

Never open or remove the protective devices of the chain drive or belt drive while the tractor engine is running and the PTO drive shaft is connected/the hydraulic drive is connected.



Danger of fingers and/or hands being cut/torn off altogether. Keep away from exposed moving parts that are part of the work process!

It could cause serious injury, possibly leading to the loss of body parts.

- Never insert your hands or arms into the hazardous area while the tractor's engine is running and the PTO drive shaft and/or hydraulic system are connected.
- Wait until the machine's moving parts have come to a complete standstill before you reach into the hazardous area with your hand and/or arm.



Risk of the tractor and machine unexpectedly being started and rolling away while work is being carried out on the machine, such as installation, set-up, troubleshooting, cleaning, maintenance and repair work.

There is a risk of serious injury or even death.

- Before any intervention on the machine, protect the tractor and the machine against being unintentionally started and against unintentional rolling away.
- Read the relevant sections in the user manual and follow the instructions.



Danger of feet being cut or torn off altogether. Keep away from exposed moving parts that are part of the work process!

It could cause serious injury, possibly leading to the loss of body parts.

- Keep your feet away from the hazardous area while the tractor engine is running and the PTO drive shaft and/or hydraulic system are connected.
- Wait until the machine's moving parts come to a complete standstill before you place your foot in the hazardous area.



Danger of the whole body becoming trapped due to the machine unfolding.

This danger can cause serious injury and even death.

- Keep a safe distance from the machine's moving parts while the tractor engine is running.
- Also make sure that other people keep a safe distance from the moving parts of the machine.

2.5 Operator's responsibilities

It is the operator's responsibility to ensure the machine is used safely. If the operator does not obey the safety instructions and rules, serious physical injury and major damage to the machine and the surroundings could be the result.

The operator must

- always be trained and qualified to operate the machine,
- remain alert and avoid hazardous situations,
- always conduct an inspection before use,
- conduct functional tests,
- check the workplace,
- keep bystanders at a safe distance,
- use the machine only for its intended purpose,
- wear the correct protective equipment and work clothing,
- not work under the influence of medicines, alcohol or drugs,
- be fully aware of the safety and usage rules, and
- know what the local government and official body instructions and rules are.

3 Residual risks



The people operating the machine are responsible for ensuring the work is carried out safely.



Every machine has inherent hazards. It is therefore always recommended to exercise the greatest caution when working.

Even if all the safety precautions are taken and the machine is used in accordance with the regulations, there are still residual risks:

Residual risks

- Sections of the machine folding out, which may cause an injury.
- Contact with rotating parts of the machine.
- Material being ejected from the machine, which may cause an injury.
- Hinged parts, which may cause body parts being pinched.
- Human errors (e.g. fatigue, mental overload, etc.)

4 General description of machine

The machine has been designed for professional use:

- On sports fields and golf courses

The machine is constructed as follows: Some parts are available as an optional extra.











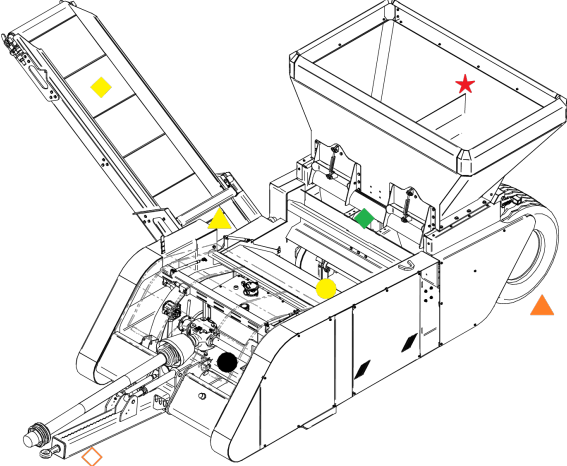
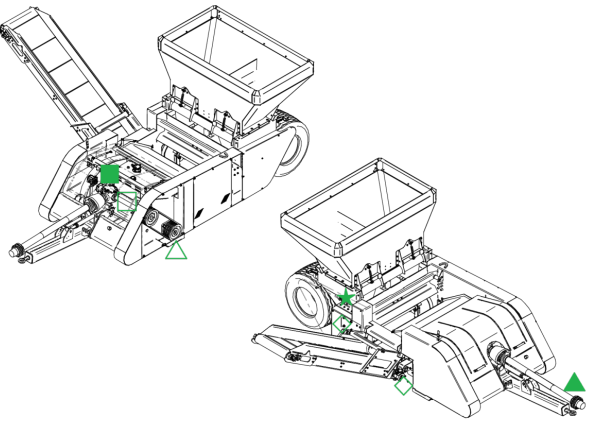

Components	Drive
	
<ul style="list-style-type: none"> •  Digging rotor •  Wheel set •  Sand belt •  Output belts •  Lateral belt •  Feed belt •  Sand bunker •  Drawbar 	<ul style="list-style-type: none"> •  Main gearbox •  Chain drive •  V-belt drive •  Hydraulic drive

Table 1: Machine parts and drive

Depending on the model, the machine functions are as follows:

- Restoring/maintaining stretches of grass
- Creating trenches in stretches of grass
- Applying sand into the trenches created
- Creating improved drainage
- Stripping the top layer
- Fraise mowing soil
- Transporting away loosened material
- Buffering the sand to be dealt with

A tractor provides the power needed to drive and tow the machine.

The power of the tractor is transferred to the machine via a PTO drive shaft

The PTO shaft must rotate at: 540 rpm

The machine is operated from the tractor driver's seat

5 Machine specifications

5.1 TD1000

		TD1000	
Dimensions			
Working width	[mm] (")	1000	39.5
Machine width (operational)	[mm] (")	3975	156.5
Machine width	[mm] (")	2240	88.2
Machine length	[mm] (")	4990	196.5
Machine height (on legs)	[mm] (")	2850	112.2
Distance between the wheel trenchers	[mm] (")	1000	39.5
Chisel width	[mm] (")	40	1.6
Weight			
Machine weight	[kg] (lbs)	2350	5170
Volume			
Sand bunker	[m3] [ft3]	1.33	47
Working speed			
Max. working speed	[km/h] (mph)	4.0	2.5
Working depth			
Max. working depth	[mm] (")	260	10.2
Power			
Min. power	[kW(pK)]	40(55)	
Max. power	[kW(pK)]	66(90)	
PTO drive shaft			
Drive train rotational speed	[/min] (rpm)	540	
PTO drive shaft type		W2400	
Torque limiter protection	[Nm] (lbf ft)		
Supply lines			
Electric	[V]	12	
Max. hydraulic pressure	[bar] (psi)	200	2900
Noise level			
Noise level	dB(A)	< 80	

6 Loading and unloading the machine



The machine has no lifting points



When the machine is transported with a low loader, it should be driven on to the low loader with a tractor

7 Putting the machine into operation



The user must have read through the whole contents of this manual and must follow to the letter the instructions therein.



20% of the unladen weight of the tractor must always rest on the front axle.



A PTO drive shaft of the wrong length may cause serious damage to the tractor and the machine. This would invalidate the CE marking of the PTO drive shaft [Putting the PTO shaft into operation](#) on page 23



Connect the overload clutch according to the instructions provided by the manufacturer of the PTO drive shaft.



Check whether the clearance around the PTO drive shaft is sufficient whatever the operating conditions. The PTO drive shaft will become damaged if there is too little clearance.

Procedure

1. Check:
 - That all bolted connections are tight
 - The oil level in the gearbox(es)
 - The oil level in the hydraulic tank
 - The hydraulic system for defects
2. Do **not** connect the PTO drive shaft yet
3. Carefully read the manufacturer's instructions for the PTO drive shaft
4. Shorten the PTO drive shaft [Putting the PTO shaft into operation](#) on page 23

7.1 Putting the PTO shaft into operation

The PTO shaft is an essential part of the machine.

There are a number of matters that need to be watched out for:

- See PTO drive shaft manual
- or <https://www.walterscheid-group.com/mediaportal/#downloads> Go to tab Walterscheid

Points of attention

1. The length of the PTO shaft.
 - With the shortest operating distance between the , the PTO shaft must still be able to slide in by 40 mm / 1.6 inch . In this, account must be taken of:
 - The smallest turning circle of tractor and machine
 - The minimum profile overlap is: See PTO shaft manual
2. Attach overloading/freewheel clutch or bolt connection (conical) at the machine end

8 Transport



20% of the unladen weight of the tractor must always rest on the front axle.

The machine may be transported on the public road while on the tractor.

Information concerning local traffic regulations must be obtained in advance.

This information could include matters such as:

- Maximum transport width;
- Maximum axle load;
- Lighting to be shown;
- Use of warning signs.

Before the tractor-machine combination goes on a public road at least check the following:

1. That the lighting works, is undamaged and properly visible
2. That the braking system works properly
3. That the supply lines are correctly connected
4. That the conveyor belts are folded in (and secured)

9 Working with the machine



The machine may only be used and maintained by persons who are familiar with the machine and have been made aware of the risks. No-one who could not be expected to make correct use of the machine is to be permitted to commission or operate the machine.



Before carrying out maintenance work or changing the machine's settings, it must have come to a complete standstill. The tractor's engine must be switched off and the key must have been removed from the ignition.



The operating speed must be adjusted to suit the soil and working conditions.



The machine is only suitable for treating soil and fields that are free of obstacles, such as stones, tree stumps, steel objects, etc.



Risk of crushing during folding and unfolding of the machine.



Only engage the PTO if there is nobody in the machine's danger zone.



While working with the machine, never depress the clutch pedal, nor take the tractor out of gear. The machine could actually push the tractor forward. This could lead to hazardous situations.



It is not permitted to stand on the machine or to stand within the range of the machine while the machine is in use. This also applies during transport.



Take into account the permissible angle rotations of the rotating PTO drive shaft.



Immediately turn off the PTO if the raised machine runs erratically.

9.1 Tractor settings



- Ensure the tyre pressures are equal
- Select the correct PTO speed: 540 rpm
- Engage the creep gear

9.2 Coupling the machine

In order to use the machine it must first be coupled up.



1. Check that the PTO drive shaft slides in and out easily (lubricate!)
2. Secure the tractor to prevent unintended starting or rolling away
3. Connect the PTO shaft
4. Connect supply lines: hydraulic, electrical or air
5. Check whether the clearance around the PTO drive shaft is sufficient whatever the operating conditions. The PTO drive shaft will become damaged if there is too little clearance.
6. Check that all supply lines are properly connected so that all machine function operate correctly

9.3 Machine settings

9.3.1 TopDrain operation

Procedure	Illustration
<p>The following functions are operated via three double-action valves:</p> <ul style="list-style-type: none"> ▲ Moving the drawbar and wheel set ● Extending and retracting the transport belt ■ Turning the sand belt on and off 	
<p>The following machine components are simultaneously turned on or off via the PTO:</p> <ul style="list-style-type: none"> ▲ Digging rotor ● Discharge belts ■ Sand mill 	
<p>The speed of the sand belt is set at the front of the machine using the:</p> <ul style="list-style-type: none"> ● rotary button 	
<p>There is a vibration motor under the sand hopper.</p> <ul style="list-style-type: none"> The vibration motor is operated by means of a switch. The vibration motor may only be used 66% of the time. 	

Table 2: TD1000

9.3.2 Adjustable drawbar

The adjustable drawbar serves to adjust the working depth, which is described below. But also to raise and lower the machine.

Procedure	Illustration
<ol style="list-style-type: none">1. Close the taps of the wheel set's hydraulic cylinders.2. Use the drawbar's hydraulic cylinder to raise the machine.3. Unscrew the nuts.4. Lower the machine to the correct working depth.5. ▲ Tighten the nut until it touches the stop.6. ▲ Use the nut to lock the nut ▲	 A technical line drawing of an adjustable drawbar assembly. It features a long, tapered metal bar with a circular eyelet at one end. A hydraulic cylinder is mounted on top of the bar. A locking nut is positioned on the cylinder, and a green triangle points to it. Another green triangle points to a stop on the bar. The drawing is shown from a perspective view.

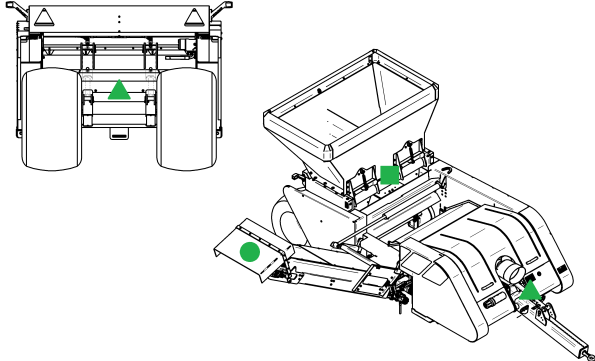
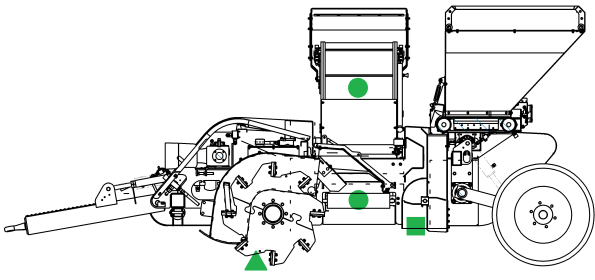
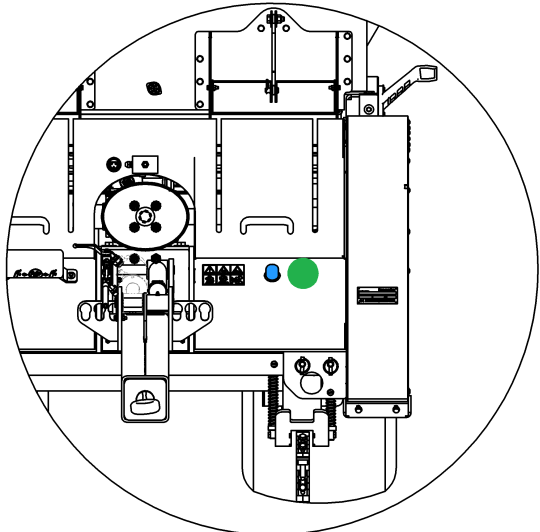
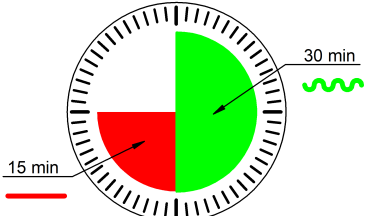
Table 3: Adjustable drawbar

9.3.3 Wheel set

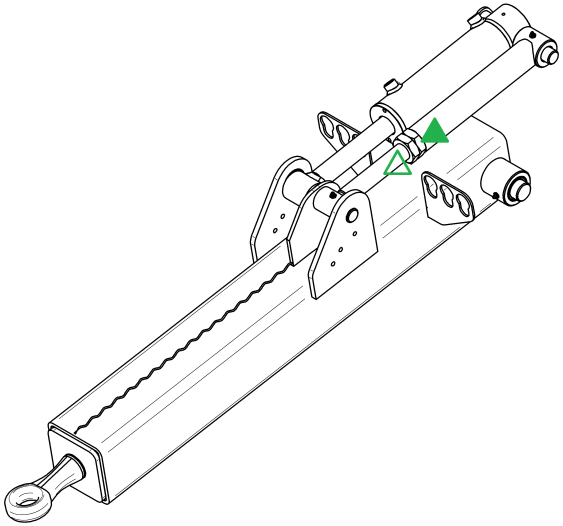

Work may only be carried out under a raised machine if the machine has been properly supported.

Procedure	Illustration
<ol style="list-style-type: none"> 1. ▲ Close the tap of the wheel set's hydraulic cylinders. 2. ● Open the valves on the hydraulic rams. 3. Bring machine to correct height using hydraulic rams 4. ■ Close valves on hydraulic rams 5. ▲ Close ball valve. 	

Table 4: Wheel set

9.3.4 Sand supply system



When the sand hopper is filled, it is forbidden for people to be within the reach of the machine. It is also forbidden to climb into the sand hopper.



When filled with sand the machine weighs approx. 5750 [kg] 12650 (lbs)

Procedure	Illustration
<p>Rough adjustment of the sand volume</p> <p>1. ▲ Adjust the reducing valve on the sand hopper</p>	
<p>Fine adjustment of the sand volume</p> <p>1. ● The rotary button can be used to adjust the speed of the sand belt.</p>	

Table 5: Sand supply system



An excess of sand must be added. The excess of sand is compacted by the wheels. This prevents subsidence after tillage.

9.4 Starting and stopping work and settings

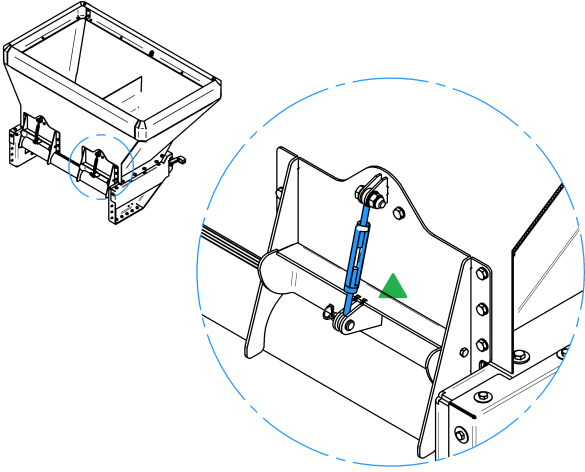
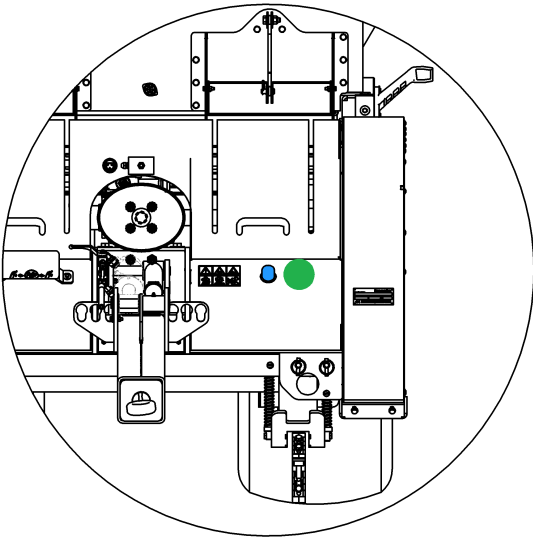
Working with the machine is described in the two tables below. Actions that recur during every job for starting and stopping are shown **printed in bold**. One-off settings are printed normally. Some of the instructions may concern an optional extra that your machine may not have.



The machine must never be turned on when the driven rotor is placed on the ground. This can result in serious damage to the tractor and the machine.

1.	Check that the correct PTO speed is engaged: 540
2.	Output belt from transport position to working position
3.	The working depth depends on the position of the drawbar and the wheel set. Wheel set on page 30 Adjustable drawbar on page 29
4.	Drive forwards
5.	Engage the PTO just before the rotor contacts the ground
6.	Engage sand belt
7.	Gradually increase the engine speed and the driving speed.
8.	After 20 metres, check the machine's working depth.
9.	Also see the depth indicator above the digging rotor
10.	If the working depth is correct, go to next step, otherwise change the working depth <ol style="list-style-type: none"> Readjust the height of the adjustable drawbar and wheel set Wheel set on page 30 Adjustable drawbar on page 29 Recheck working depth. If working depth is correct, continue work or go through this step again
11.	Use the wheel set to level the machine Wheel set on page 30

Table 6: Starting the machine and configuring the settings

1.	Reduce the travelling speed
2.	Reduce the engine speed
3.	Disengage the PTO during lifting
4.	Turn off the sand belt
5.	After completing the work, put the feed belt into the transport position

Table 7: End of job, stopping the machine (and settings)



The machine's working speed depends on:

- The depth of the tillage
- Type of soil
- Soil condition (wet, dry)
- Compacting (disruptive layers)



The trenches should preferably be made at right angles to the existing drainage. As the existing drainage trenches are filled with coarse sand to about 15 cm under the surface, contact is made between the surface and the existing drainage. The water is drained away more quickly.



The machine has a work depth indicator



The sand hopper must be filled with clean sand which does not contain any stones or other contamination.

*)= If present **)= Optional

9.5 Blocking the machine



Apply the tractor's handbrake so that it cannot roll away.



Work may only be carried out under a raised machine if the machine has been properly supported.



Before carrying out maintenance work or changing the machine's settings, it must have come to a complete standstill. The tractor's engine must be switched off and the key must have been removed from the ignition.



Be aware of residual mechanical, hydraulic, pneumatic and electrical energy present in the machine.

The machine may come to a halt because it is full, or because of stones or other obstacles. If overloaded, the oil passes through the pressure relief valve and the hydraulic system will stop.



Make sure the sand scoops are not blocked



1. Immediately disengage the PTO drive shaft
2. Raise the machine fully out of the ground.
3. Place the machine on the ground and turn off the tractor engine.
4. Remove the obstacle from the ground or the machine.
5. Start tilling on the newly prepared section of soil.

Procedure	Illustration
<ol style="list-style-type: none"> 1. Lift the machine 2. Close the drawbar's hydraulic tap. 3. ▲ Fit the support feet to the rotovator's cover. 4. Open the drawbar's hydraulic tap. 5. Turn on the PTO. 6. Slowly lower the machine. 7. The digging rotor cleans the cover. 	

Table 8: Cleaning the rotovator's cover

9.6 Uncoupling the machine



Be aware of residual mechanical, hydraulic, pneumatic and electrical energy present in the machine.



1. Place the machine on a flat, stable surface
2. During all operational activities, make sure the machine cannot roll away unintentionally.
3. Secure the tractor to prevent unintended starting or rolling away
4. Disconnect the PTO shaft
5. Disconnect supply lines: hydraulic, electrical or air

10 Maintenance of the machine



The machine may only be used and maintained by persons who are familiar with the machine and have been made aware of the risks. No-one who could not be expected to make correct use of the machine is to be permitted to commission or operate the machine.



Before carrying out maintenance work or changing the machine's settings, it must have come to a complete standstill. The tractor's engine must be switched off and the key must have been removed from the ignition.



Never use your hand or fingers to try to stop a leak in the hydraulic system. Fluid escaping under pressure (hydraulic oil) could enter the body through the skin and cause serious injury. Consult a doctor immediately in case of wounds from hydraulic oil!



Avoid dangerous situations. Repair broken or worn parts before using the machine.



Be aware of residual mechanical, hydraulic, pneumatic and electrical energy present in the machine.



Work may only be carried out under a raised machine if the machine has been properly supported.



For reasons of quality and safety, only use original **Imants®** parts.

10.1 Daily inspection

<p>General</p> <ul style="list-style-type: none"> • Warning stickers • Loose bolted connections • Gaskets and seal washers for leaks • Tyre pressure • All components of the hydraulic system • Conveyor belts 	<p>Guards</p> <ul style="list-style-type: none"> • PTO drive shaft guard(s) • Chain drive guard(s) • V-belt drive guard(s) • Skid under chain case(s)
<p>Wear parts</p> <ul style="list-style-type: none"> • TD Chisel • TD Sand supply sand scoop 	<p>Drive</p> <ul style="list-style-type: none"> • Oil level in gearbox(es) • Hydraulic tank • Oil level in hydraulic pump gearbox(es) • Chain tensioner(s) • V-belt tensioner(s) • Vent nipples

10.2 Drive train

The drive train comprises the following components:

10.2.1 PTO drive shaft



Keep the PTO drive shaft clean. Lubricate sliding parts so that the PTO drive shaft can slide in and out easily.

- Consult the PTO shaft manual for its maintenance
- of <http://www.gkn-walterscheid.de/downloads/anleitungen>

10.2.2 Gear box



The gearbox is filled with running-in oil. This should be changed after **50** operating hours. See oil type in table below



Position indications on the machine are always expressed as seen from the rear of the machine.



Dispose of the waste oil in an environmentally responsible manner. To do so, follow the local statutory regulations in force



Check the oil level

1. Set the gear box to be horizontal
2. The oil level must be in the middle of the sight glass of the level plug
3. The oil level should be at the bottom of the level plug



Change the oil

1. Open the protective cover fitted over the gearbox and hydraulic system
2. Place a collection pan under the gear box
3. Check the vent plug for correct operation
4. Open the drain plug
5. Drain all the oil
6. Screw the drain plug back in and fill the gearbox
7. Screw the vent and filler plugs back in
8. Close the protective cover

10.2.2.1 Middle gearbox

Symbol	Description	Gearbox type
●	Vent plug / filler plug	
▲	Level plug	
■	Drain plug	

Table 9: Oil level legend

Gearbox type	Oil type	Oil volume	Maintenance interval
033705: Brevini ML32	MobilGear 600XP320	0.15 [L] / 0.04 (USgal)	12 months or 500 operating hours
021678: S2070	MobilGear 600XP320	1.7 [L] / 0.45 (USgal)	12 months or 500 operating hours

Table 10: Gearbox filling details and maintenance interval

10.2.3 Hydraulic system



Dispose of the waste oil in an environmentally responsible manner. To do so, follow the local statutory regulations in force



Check the oil level

1. Make sure the machine is level horizontally.
2. The oil level must be at 3/4 of the way up the gauge glass.



Change the oil

1. Open the protective cover fitted over the gearbox and hydraulic system
2. Place a container under the hydraulic tank.
3. Open the drain plug
4. Drain all the oil
5. Refit the drain plug and fill the hydraulic tank until the level reaches 3/4 of the way up the gauge glass.
6. Refit the cap.
7. Close the protective cover

Symbol	Description	Illustration
●	Filler cap	
▲	Gauge glass	
	Drain plug on the bottom of the hydraulic tank	

Table 11: Hydraulic tank oil level

Oil type	Oil volume	Maintenance interval
Total T68	60 [L] / 15.9 (USgal)	24 months or 2000 operating hours

Table 12: Hydraulic tank filling details and maintenance interval

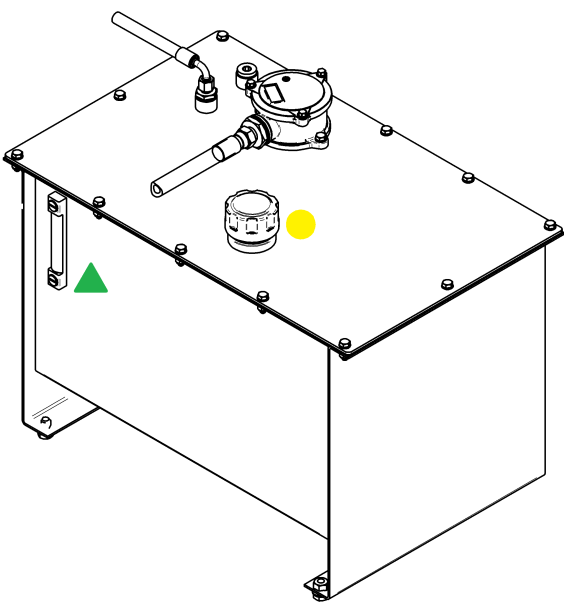

Change the filter after the first **50** operating hours. See the table below for the maintenance interval after the first filter change.





Procedure	Maintenance interval	Illustration
<ol style="list-style-type: none"> 1.  Remove the filter element. 2.  Fit a new filter. 3.  Fit the filter element. 	12 months or 500 operating hours	 

Table 13: Replacing the filter element and the maintenance interval

10.2.4 Tension the chain

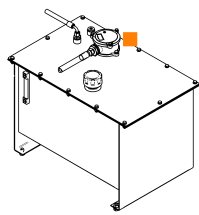

Before carrying out maintenance work or changing the machine's settings, it must have come to a complete standstill. The tractor's engine must be switched off and the key must have been removed from the ignition.



Be aware of residual mechanical, hydraulic, pneumatic and electrical energy present in the machine.



Work may only be carried out under a raised machine if the machine has been properly supported.



For reasons of quality and safety, only use original **Imants®** parts.



Replace the chain + sprockets + chain grease at the same time



Procedure	Illustration
<ol style="list-style-type: none"> 1. Remove the guard 2.  Slacken bolt connection a few turns 3.  Tension chain 4. Bolt connection torque:  M10 (8.8) 49[Nm] / 36(lbf ft) 	

Table 14: Tensioning the sand belt chain

10.2.5 Tensioning the V-belt



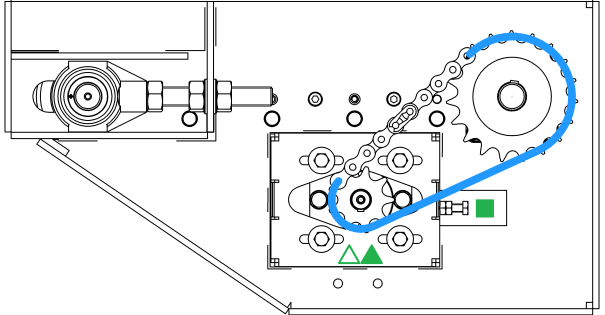

Procedure	Illustration
<ol style="list-style-type: none"> 1. Open the cover above the gearbox and the cover on the front left-hand side. 2.  Slacken bolt connection a few turns 3. This applies to the gearbox and the top V-belt pulley. 4.  Use the bolt. 5.  Use the bolt to align the V-belt pulley and the gearbox. Use a ruler for the top and bottom pulleys. First, unscrew the lock nut. 6. Tighten the lock nuts. 7. Bolt connection torque: 8. Close the covers. <p> M16 (8.8) 210 [Nm] / 155 (lbf ft)</p>	

Table 15: Tensioning the V-belt

10.3 Periodic maintenance and inspection: Lubrication of machine Checking the vent nipples

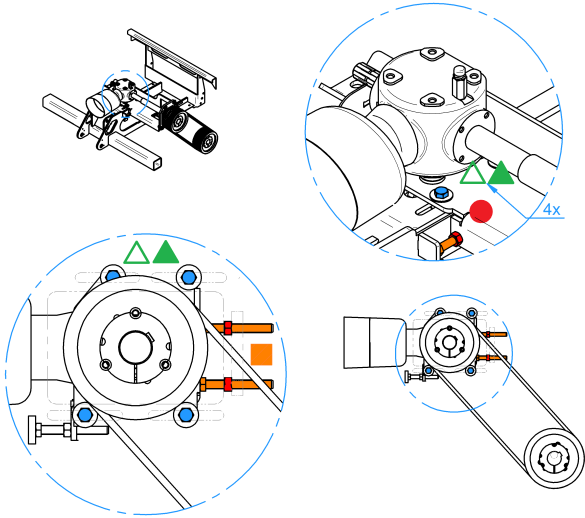
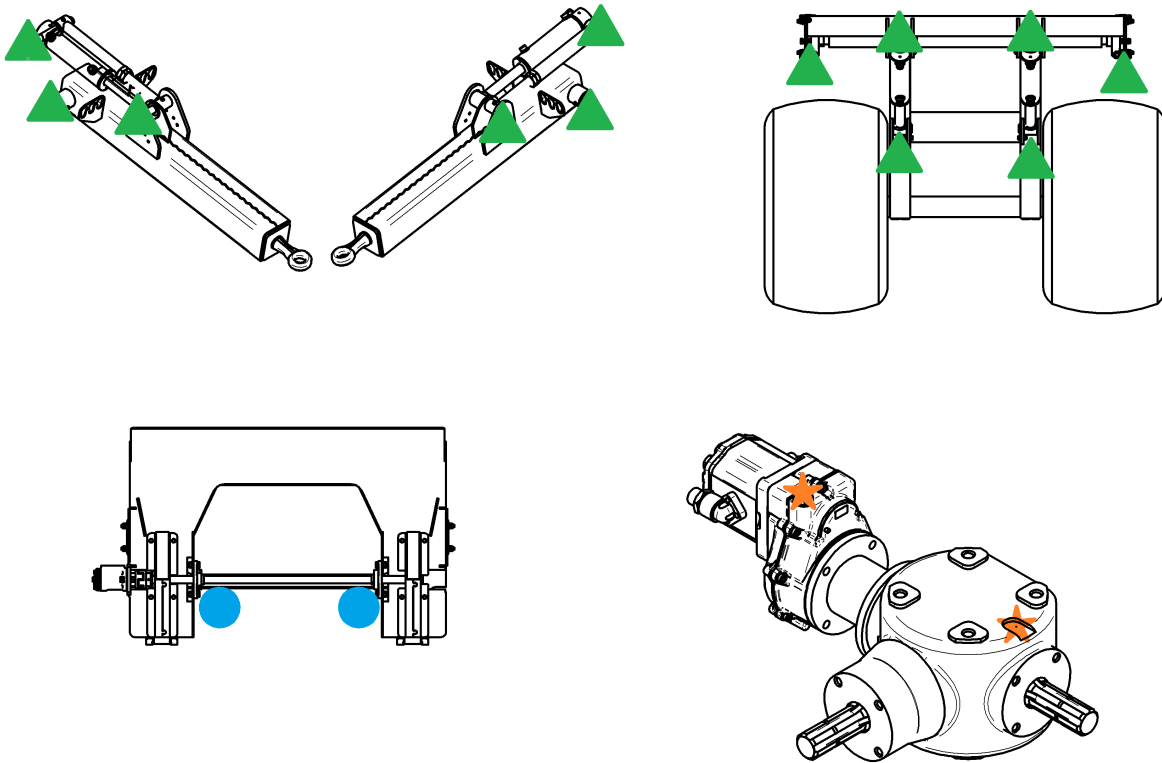

Do **not** lubricate with an electric or pneumatic grease gun.

Symbol	Number of grease nipples	Maintenance interval
●	2	8 operating hours
▲	12	40 operating hours

Table 16: Lubrication of machine

Symbol	Number of bleed nipples	Maintenance interval
★	2	12 months or 500 operating hours

Table 17: Checking the vent nipples

10.4 Conveyor belts



Before carrying out maintenance work or changing the machine's settings, it must have come to a complete standstill. The tractor's engine must be switched off and the key must have been removed from the ignition.



Do not leave the machine in the sun after use. This shortens the service life of the transport belts.

10.4.1 Tensioning: general information

Procedure	Illustration
<ol style="list-style-type: none">1. Draw two lines on the slack conveyor belt a distance of 1,000 mm apart2. Tension the conveyor belt.3. The conveyor belt is correctly tensioned when the lines are 1,005 mm apart	<p>The illustration shows three stages of the tensioning process. Stage 1 shows a slack conveyor belt with a red 'X' in the center. Stage 2 shows the belt with two vertical lines drawn on it, 1000 mm apart, with a pencil icon. Stage 3 shows the belt tensioned, with the distance between the lines now 1005 mm, marked with a green checkmark and a wrench icon.</p>

Table 18: Tensioning the conveyor belts: general information

10.4.2 Tensioning the supply conveyor

Procedure	Illustration
<ol style="list-style-type: none"> 1. ■ Make sure the transport conveyor remains in the middle of the drive roller on the drive side. 2. ▲ Unscrew the nuts on both sides. 3. ● Use both nuts to evenly tension the tensioning roller. The drive roller and the tensioning roller must be parallel to each other. 4. ▲ Tighten the nuts on both sides. 5. After tensioning, run the transport conveyor at a low rotational speed. 6. Check whether the transport conveyor continues to run in the middle. 7. If not, align it. 	

Table 19: Tensioning the supply conveyor

10.4.3 Tensioning the lateral conveyor

Procedure	Illustration
<ol style="list-style-type: none"> 1. ■ Make sure the transport conveyor remains in the middle of the drive roller on the drive side. 2. Remove the cover on the left-hand side. 3. ▲ Unscrew the nuts on both sides. 4. ● Use both nuts to evenly tension the tensioning roller. The drive roller and the tensioning roller must be parallel to each other. 5. ▲ Tighten the nuts on both sides. 6. After tensioning, run the transport conveyor at a low rotational speed. 7. Check whether the transport conveyor continues to run in the middle. 8. If not, align it. 9. Fit the cover. 	

Table 20: Tensioning the lateral conveyor

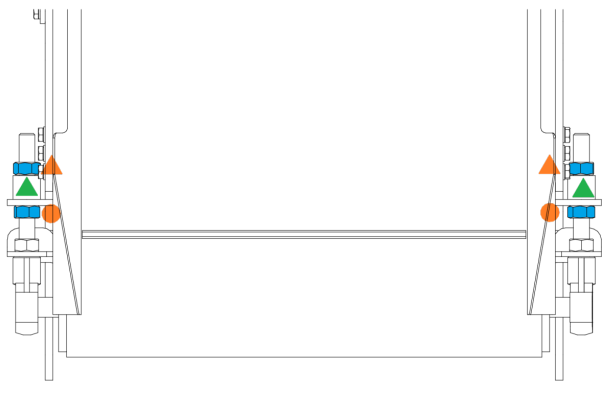
10.4.4 Tensioning the sanding belt

Procedure	Illustration
<ol style="list-style-type: none">1. Remove the cover on the left-hand side.2. ▲ Unscrew the nuts on both sides.3. ● Use both nuts to evenly tension the tensioning roller.4. ▲ Tighten the nuts on both sides.5. Fit the cover. <p>▲ M24 (8.8) 710 [Nm] / 525 (lbf ft)</p>	

Table 21: Tensioning the sanding belt

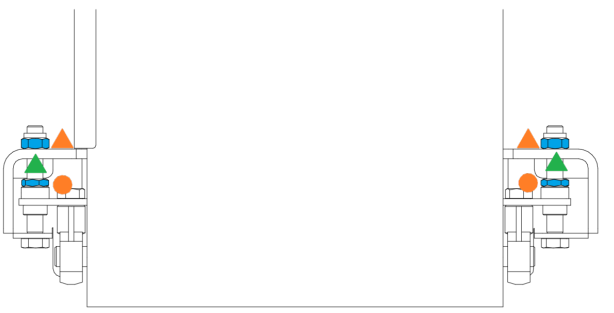
10.5 Wear parts

10.5.1 Replace TD Chisel

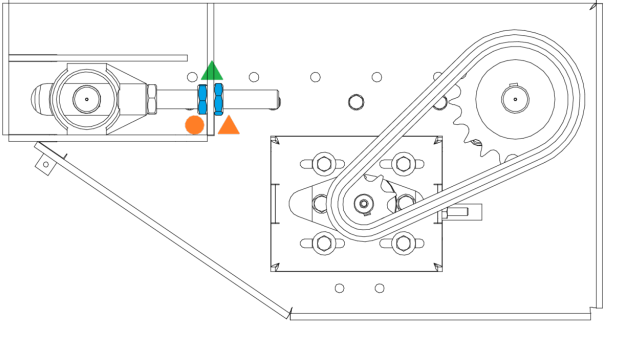

Before carrying out maintenance work or changing the machine's settings, it must have come to a complete standstill. The tractor's engine must be switched off and the key must have been removed from the ignition.



For reasons of quality and safety, only use original **Imants®** parts.



Dispose of any worn components in an environmentally responsible manner. Always follow the locally applicable statutory regulations.



Procedure	Procedure
<ol style="list-style-type: none"> 1. ▲ Remove bolt connection 2. Remove TD Chisel 3. Clean wear and tear part holder 4. Install TD Chisel 5. ▲ Fit bolt connection 6. Bolt connection torque: ▲ M10 (8.8) 49 [Nm] / 36 (lbf ft) 	

Table 22: TD Chisel

10.5.2 Replace TD Sand supply sand scoop



Before carrying out maintenance work or changing the machine's settings, it must have come to a complete standstill. The tractor's engine must be switched off and the key must have been removed from the ignition.

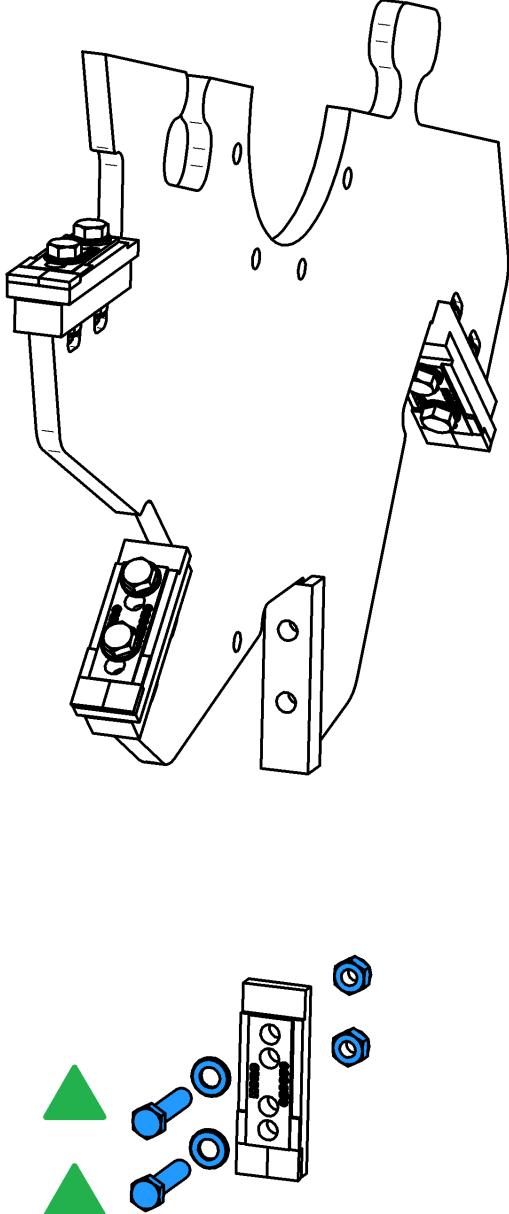

For reasons of quality and safety, only use original **Imants®** parts.



Dispose of any worn components in an environmentally responsible manner. Always follow the locally applicable statutory regulations.



Procedure	Illustration
<ol style="list-style-type: none"> 1. ▲ Remove bolt connection 2. Remove TD Chisel 3. Clean wear and tear part holder 4. Install TD Chisel 5. ▲ Fit bolt connection 6. Bolt connection torque: <p>▲ M8 (8.8) 25 [Nm] / 18.5 (lbf ft)</p>	

Table 23: TD Sand supply sand scoop

11 Cleaning



Never clean a machine while it is in operation. There is a risk of serious injury or even death.



Carefully check hydraulic hoses and electrical cables.



Never treat hydraulic hoses and electric cables with gasoline, benzene, petroleum or mineral oils.



Lubricate the machine after cleaning it. Especially after the machine has been cleaned using a high-pressure cleaner/steamer or fat-soluble agents.



Observe the legal requirements concerning the use and disposal of cleaning agents.

When cleaning with a high-pressure cleaner, you must always follow the instructions below:

1. Maximum permitted pressure is 100 bar.
2. The maximum temperature is 50°C
3. Do not clean the electrical components.
4. Never direct the jet of the high-pressure cleaner or steamer directly at the stickers, lubricating points or bearings.
5. Keep the high-pressure cleaner/steamer a minimum distance of 600 mm away from the machine
6. Observe the safety regulations for the use of high-pressure cleaners.

12 Decommissioning

When the machine is decommissioned, the parts can be sorted as follows:

1. Metals
2. Plastics
3. Oils and greases



Dispose of the sorted materials in an environmentally responsible manner. Always follow the locally applicable statutory regulations.

13 Warranty

IMANTS BV warranty information

(A) Warranty

IMANTS BV guarantees that none of the products that it manufactures has any material faults and IMANTS BV issues a warranty for the manufactured products at the time of shipment, which is valid for a period of twelve (12) months from the date of delivery to the customer. IMANTS BV delivers replacement parts, free of charge, for all parts that IMANTS BV considers to be faulty at the time of shipment. Alternatively, IMANTS BV can opt to repair such components or have such components repaired on its behalf on the condition that such components are returned on request to the factory at Turnhoutseweg 29, 5541 NV, Reusel, the Netherlands. The transport costs for the return shipment must be paid in advance.

This warranty does not apply to any products that have been subject to incorrect use, incorrect application, negligence (including, but not limited to, incorrect maintenance), an accident, incorrect installation, a modification (including, but not limited to, the use of components or add-on components for which permission has not been granted), an alteration or repair. Motors and all accessories that are delivered with products from IMANTS BV but which are not manufactured by IMANTS BV are not covered by the warranty issued by IMANTS BV. They are only sold with the explicit warranty, if there is one, issued by the manufacturer concerned. THE ABOVE REPLACES ALL OTHER WARRANTIES, EITHER EXPLICITLY OR IMPLICITLY (INCLUDING GUARANTEES OF SALEABILITY AND SUITABILITY OF ANY PRODUCT FOR A CERTAIN PURPOSE), AS WELL AS ANY OTHER LIABILITY OF IMANTS BV.

(B) Limitation of liability

It is expressly stated that the liability of IMANTS BV for its products, either on account of termination of the warranty, negligence, strict liability or otherwise, is limited to the delivery of replacement components and that IMANTS BV is not liable for any injury, loss, damage or expenses, neither directly or indirectly, including, but not limited to, a loss of use, income, profit or production, or higher operational costs, or decay or damage of materials resulting from the sale, installation, use, inability to use, or repair or replacement of IMANTS BV products.

Every operation that is expressly forbidden in the operating instructions or instruction manuals that are provided with the machine, and any alteration or assembly procedure that is not recommended by or is not permitted according to the operating or maintenance instructions invalidates such warranty.

(C) Registration

THIS WARRANTY IS INVALID UNLESS THE REGISTRATION FORM IS COMPLETEED AND RETURNED TO THE FACTORY AT TURNHOUTSEWEG 29, 5541 NV, REUSEL, THE NETHERLANDS, WITHIN 30 DAYS AFTER DELIVERY OF THE UNIT TO THE CUSTOMER.

No component must be returned under warranty unless IMANTS BV has given permission for it to be returned (RGA - Return Goods Authorization).

ALWAYS STATE THE NAME OF THE COMPONENT, THE COMPONENT NUMBER AND THE SERIAL NUMBER OF THE MACHINE WHEN ORDERING COMPONENTS.

NOTE:

IMANTS BV maintains the right to make changes to the design and construction without the obligation to also make these changes to previously sold products. In the event of conflicts, the general terms and conditions of delivery and payment laid down by the Koninklijke Metaalunie are applicable.

14 Appendix/Appendices

In this part of the manual, you can find extra information about your machine

14.1 TD100 hydraulic diagram

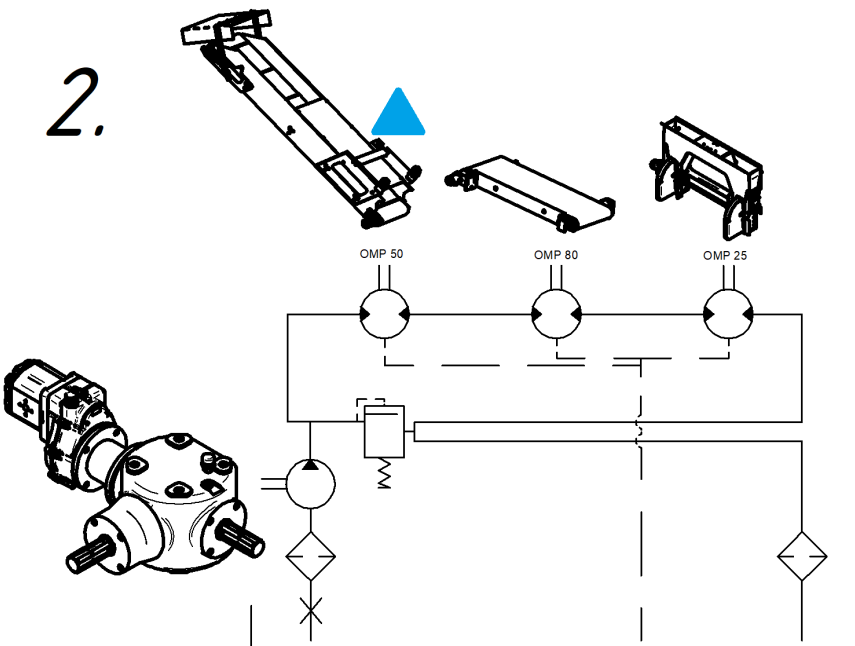
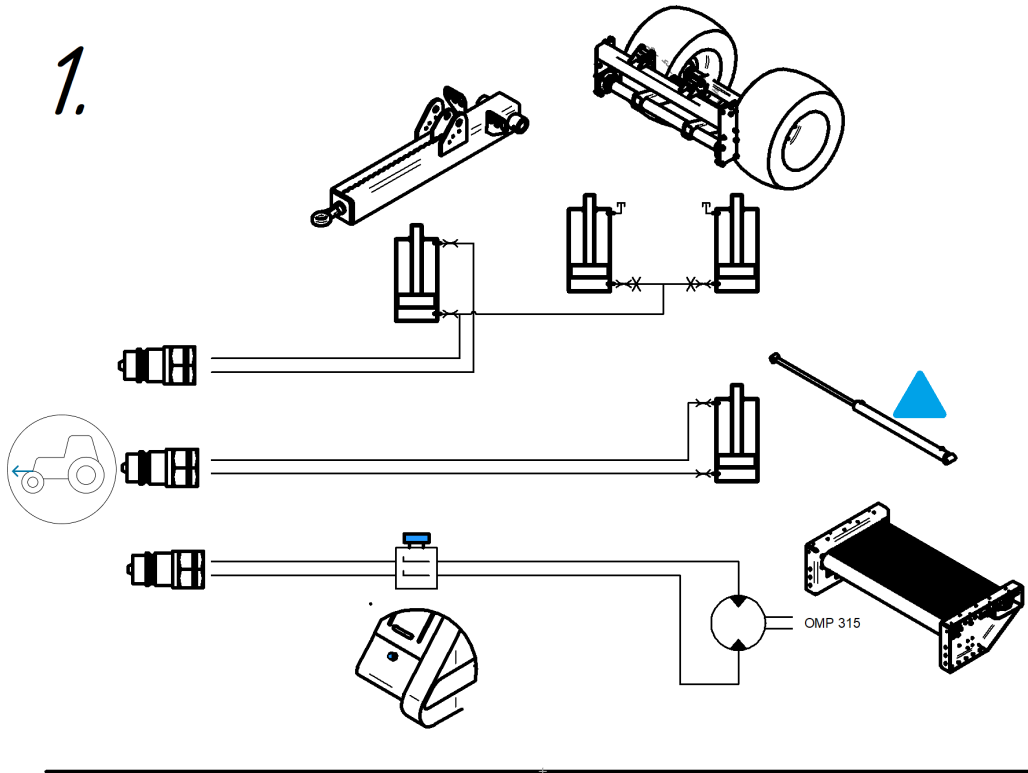

14.2 Electrical layout of 7-pin plug

The standard plug is the 7-pin plug. With correct connection, each pin has a specific function determined in advance.

Description			Illustration
1	L	Left turn signal	
2	54G	12 V	
3	31	Chassis	
4	R	Right turn signal	
5	58R	Right-hand light	
6	54	Brake lights	
7	58L	Left-hand light	

Table 24: European connection

14.3 Electrical layout for vibration motor



15 CE declaration

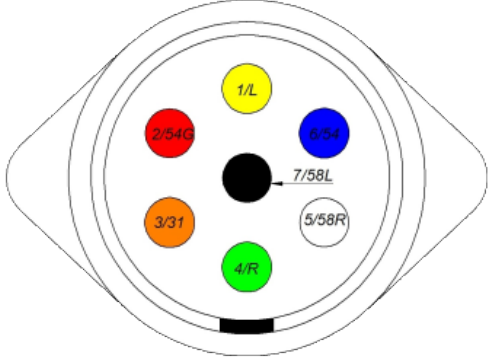
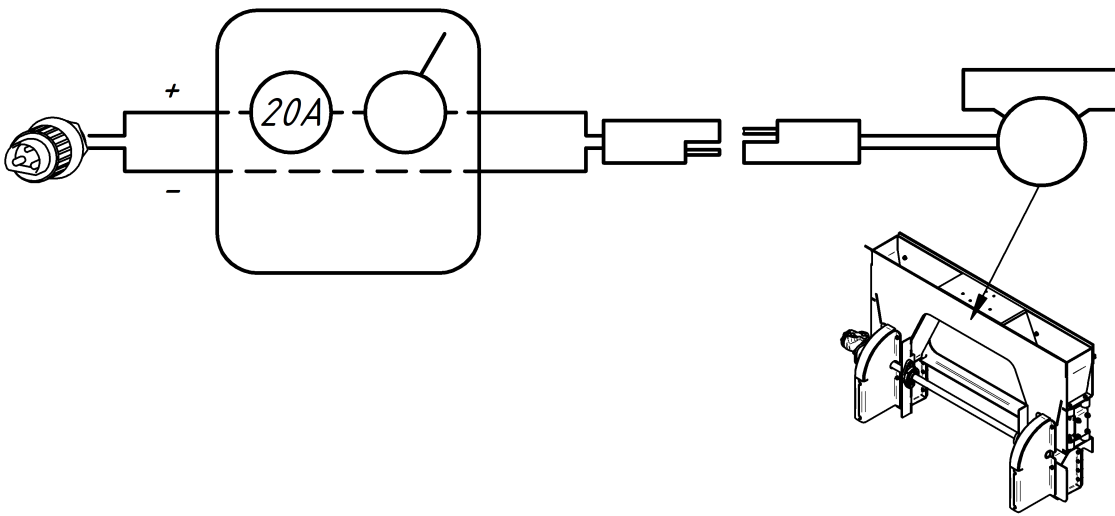

Imants® BV
Turnhoutseweg 29
5541 NV Reusel
+31 (0)497 642 433
+31 (0)497 643 205
www.imants.nl
info@imants.nl