

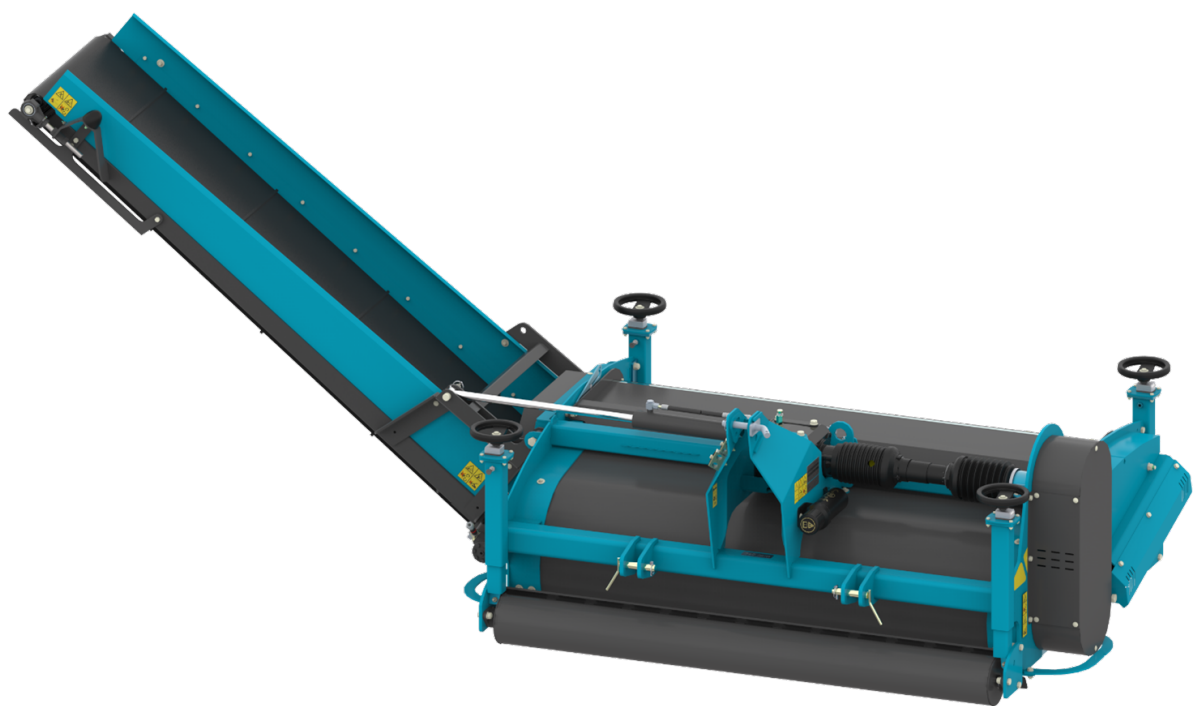

**KORO® FTM**  
**2.0 / 2.5**  
**Manual**



Copyright © **Imants® BV** 2023

**Imants® BV** reserves the right to alter parts at any desired moment, without prior or direct notification to the purchaser.

The contents of this document may equally be amended without prior warning.

For information about settings, maintenance work or repair that this document does not cover, you are recommended to contact your supplier's service department.

Great care has been put into compiling this document. **Imants® BV** cannot, however, be held responsible for any errors it may contain or any consequences they may have.

All rights reserved. Nothing in this document may be duplicated, stored in an automated database, or made public, in any form or way, whether electronic, mechanical, by photocopying, recording or in any other way, without prior written permission from **Imants® BV**. This also applies to the associated drawings and diagrams.





# Table of contents

<b>1 Foreword</b> .....	<b>7</b>
<b>2 Safety instructions</b> .....	<b>8</b>
2.1 Explanation of pictograms.....	8
2.1.1 Hazard indications.....	8
2.1.2 Meanings of pictograms.....	9
2.1.3 Meanings of operating pictograms.....	10
2.2 General safety instructions.....	11
2.3 Warning stickers on the machine.....	13
2.4 Position of the warning stickers and type plate on the machine.....	15
2.5 Operator's responsibilities.....	16
<b>3 Residual risks</b> .....	<b>17</b>
<b>4 General description of machine</b> .....	<b>18</b>
<b>5 Machine specifications</b> .....	<b>20</b>
5.1 FTM.....	20
<b>6 Loading and unloading the machine</b> .....	<b>21</b>
<b>7 Putting the machine into operation</b> .....	<b>22</b>
7.1 Putting the PTO shaft into operation.....	23
<b>8 Transport</b> .....	<b>24</b>
<b>9 Working with the machine</b> .....	<b>25</b>
9.1 Tractor settings.....	27
9.2 Coupling the machine.....	28
9.3 Machine settings.....	29
9.3.1 Counter default setting.....	29
9.3.2 Configuring the counters.....	30
9.3.3 Centre roller.....	31
9.3.4 Ballast.....	32
9.3.5 Replacing rotors.....	33
9.3.6 Aligning the pulleys.....	34
9.4 Starting and stopping work and settings.....	35
9.5 Blocking the machine.....	36
9.6 Uncoupling the machine.....	37
<b>10 Maintenance of the machine</b> .....	<b>38</b>
10.1 Daily inspection.....	39
10.2 Drive train.....	40
10.2.1 PTO drive shaft.....	40

10.2.2 Gear box.....	41
10.2.2.1 Middle gearbox.....	42
10.2.3 Tensioning the V-belt.....	43
10.3 Periodic maintenance and inspection: Checking the vent nipples.....	44
10.4 Installing the clamping bush.....	45
10.5 Conveyor belts.....	46
10.5.1 Tensioning: general information.....	46
10.5.2 Tensioning the supply conveyor.....	47
10.5.3 Tensioning the lateral conveyor.....	47
10.5.4 Replacing the supply conveyor.....	48
10.5.5 Replacing the lateral conveyor.....	48
10.5.6 Configuring the supply conveyor scrapers.....	49
10.5.7 Configuring the lateral conveyor scrapers.....	49
10.6 Wear parts.....	50
10.6.1 Replace Universe <sup>®</sup> digging blade.....	50
10.6.2 Replace TerraPlane <sup>®</sup> chisel.....	51
<b>11 Cleaning.....</b>	<b>52</b>
<b>12 Decommissioning.....</b>	<b>53</b>
<b>13 Warranty.....</b>	<b>54</b>
<b>14 Appendix/Appendices.....</b>	<b>55</b>
<b>15 CE declaration.....</b>	<b>56</b>

# 1 Foreword

First of all, we would like to congratulate you on purchasing a **Imants®** machine. You have chosen a high-quality product. If used correctly, your machine will bring you many years of enjoyment.

This Manual is an important document to ensure the machine is used correctly. It contains all the information required to use the machine safely and optimally.

We recommend that you read this Manual thoroughly and that you study and follow all the instructions before using the machine for the first time. The illustrations used in this Manual may differ from the configuration of your machine; they are merely intended to explain a working principle.

Please contact your point of sale/dealer should there be any questions or ambiguities as regards this Manual.

We update our manuals regularly. Your suggestions help us to make our manuals even more user friendly. You can e-mail your suggestions to [info@imants.nl](mailto:info@imants.nl) with 'manuals' in the subject line.

**Imants® BV** accepts no responsibility whatsoever for any damage or consequential damage due to the incorrect use of the machine.

For this Manual, it is a "Original document".

## 2 Safety instructions

The machine has been carefully designed and professionally built to allow it to be worked with safely. The CE Declaration confirms this. There are always however hazards and safety risks that cannot be excluded. The functions of the machine and its operation by the operator give rise to these hazards and risks.

This chapter covers the safety instructions and precautions, how these are brought to your attention and with which the operator must comply. It is extremely important that you are properly familiar with the safety instructions and rules and that you respect them in all circumstances!

### 2.1 Explanation of pictograms

Pictograms are present under many headings in this manual. Symbols have also been applied to the machine. In this chapter, you can see what these pictograms and symbols mean, what they refer to, or what they are warning you about.

#### 2.1.1 Hazard indications

The symbols below indicate a possible danger of personal injury. The symbol is composed of an equilateral triangle surrounding an exclamation mark.

Warning pictograms that are used in the Manual but are not present on the machine as stickers.



Warns of hazardous situations which must be avoided absolutely and are likely to result in death or serious injury.

---



Warns of a hazardous situation that, if not avoided, could lead to death or serious injury.

---



Warns of a hazardous situation that, if not avoided, could lead to slight or more significant injury.

---

This symbol is not a hazard symbol but rather an information symbol.



Provides additional information aimed at facilitating or improving the use of the machine.

---

## 2.1.2 Meanings of pictograms























Below, you can see what the illustrations in the manual mean, what they refer to, or what they are warning you about.

	Danger of personal injury		Fire hazard
	Hot surfaces		Trapping risk
	Moving parts		Leakage
	Explosive substances		Safety footwear
	Hearing protection		Gloves
	Eye protection		Clothing stipulations
	Document reference		Use of tools
	Material use		Read the manual
	Danger of becoming trapped due to being present within the lifting range		Danger of becoming trapped due to the machine lowering unintentionally
	Danger from hydraulic oil under high pressure as a result of leaking hydraulic hoses!		Max. hydraulic system pressure
	Unintentional starting and rolling away of the machine		Recycle
	Acceptable, correct		Unacceptable, wrong
	Use lifting hook		Visual inspection

### 2.1.3 Meanings of operating pictograms

Operating pictograms indicate schematically what action must be taken or what setting must be chosen.

The summary below includes all possible pictograms, which does not mean they are all used in this Manual:

	On		Off
	Hitch tension adjustment		Hitch position adjustment
	Hitch downwards		Hitch upwards
	Hitch working depth		Pressure gauge
	PTO on		PTO off
	PTO 1000 rpm		PTO 540 rpm
	Front wheel drive		Direction of travel
	Engage gear		Engine speed down
	Engine speed up		Ram in floating position
	Ram in		Ram out
	Fold out		Fold in

## 2.2 General safety instructions

---



The user must hold a valid tractor driving licence in order to operate the machine.

---



The user must be at least 16 years old, unless the local legislation stipulates a higher minimum age. The higher age limit shall prevail.

---



The user of the machine is responsible at all times for compliance with local safety regulations and guidelines.

---



The user must have read through the whole contents of this manual and must follow to the letter the instructions therein.

---



Keep this manual and that of the PTO drive shaft within reach.

---



Use the machine solely for the purpose it was designed for.

---



The machine may only be used and maintained by persons who are familiar with the machine and have been made aware of the risks. No-one who could not be expected to make correct use of the machine is to be permitted to commission or operate the machine.

---



No one should be standing between the machine and the tractor while these are being coupled or uncoupled.

---



All safety facilities must be assembled on to the machine and be in good conditions. Never remove or open a guard when the machine is running.

---



Always follow the specifications and requirements set by the manufacturer of the tractor in relation to its use. Please refer to Tractor manual.

---



Always comply with the requirements regarding the maximum load of the front and rear axles, given by the tractor manufacturer.

---



Standing on or within the range of the machine during work is prohibited. This also applies during transport.

---



The maximum load of the tractor tyres, given by the tyre manufacturer, should not be exceeded during operation of the machine.

---



Warning labels should always be legible.

---



Work may only be carried out under a raised machine if the machine has been properly supported.

---



For reasons of quality and safety, only use original **Imants®** parts.

---



Maintain the machine as indicated later in the manual. Only perform this work when the machine is at a complete stop. Remove the key from the tractor's ignition.

---



Modifications, additions or developments on or to the machine are not allowed without the written permission of Imants BV. This includes welding on load bearing parts. Without this written authorisation, Imants BV's responsibility for the CE marking is invalidated and is passed on to the buyer.

---

## 2.3 Warning stickers on the machine



See [Position of the warning stickers and type plate on the machine](#) on page 15 for the position of the warning stickers.

The warning stickers below can be found on the machine.



**Crushing hazard. Keep hands and fingers away from the exposed, moving parts of the machine!**

It could cause serious physical injury with the possible loss of a hand or an arm.

Keep your hands and arms away from the hazardous area while the tractor engine is running and the PTO drive shaft and/or hydraulic system are connected.



**Danger of hand or arm being pulled in or gripped by a powered and unprotected chain or belt drive.**

This hazard can cause serious physical injury with the possible loss of a hand or an arm.

Never open or remove the protective devices of the chain drive or belt drive while the tractor engine is running and the PTO drive shaft is connected/the hydraulic drive is connected.



**Danger of hands or arms being pulled in or locked in by the moving parts of the power transmission.**

It could cause serious injury, possibly leading to the loss of body parts.

Never open or remove the protective devices while the tractor engine is running and the PTO drive shaft and/or hydraulic system are connected.



**Read and observe the operating instructions and safety regulations before you operate the machine.**



**Risk of the tractor and machine unexpectedly being started and rolling away while work is being carried out on the machine, such as installation, set-up, troubleshooting, cleaning, maintenance and repair work.**

There is a risk of serious injury or even death.

- Before any intervention on the machine, protect the tractor and the machine against being unintentionally started and against unintentional rolling away.
- Read the relevant sections in the user manual and follow the instructions.



**Danger of feet being cut or torn off altogether. Keep away from exposed moving parts that are part of the work process!**

It could cause serious injury, possibly leading to the loss of body parts.

- Keep your feet away from the hazardous area while the tractor engine is running and the PTO drive shaft and/or hydraulic system are connected.
- Wait until the machine's moving parts come to a complete standstill before you place your foot in the hazardous area.



**Danger of the whole body becoming trapped due to the machine unfolding.**

This danger can cause serious injury and even death.

- Keep a safe distance from the machine's moving parts while the tractor engine is running.
- Also make sure that other people keep a safe distance from the moving parts of the machine.

## 2.4 Position of the warning stickers and type plate on the machine



Warning labels should always be legible.

The illustration below shows where the safety stickers and type plate are to be found on the machine

Illustration 2: Position of the pictograms and type plate

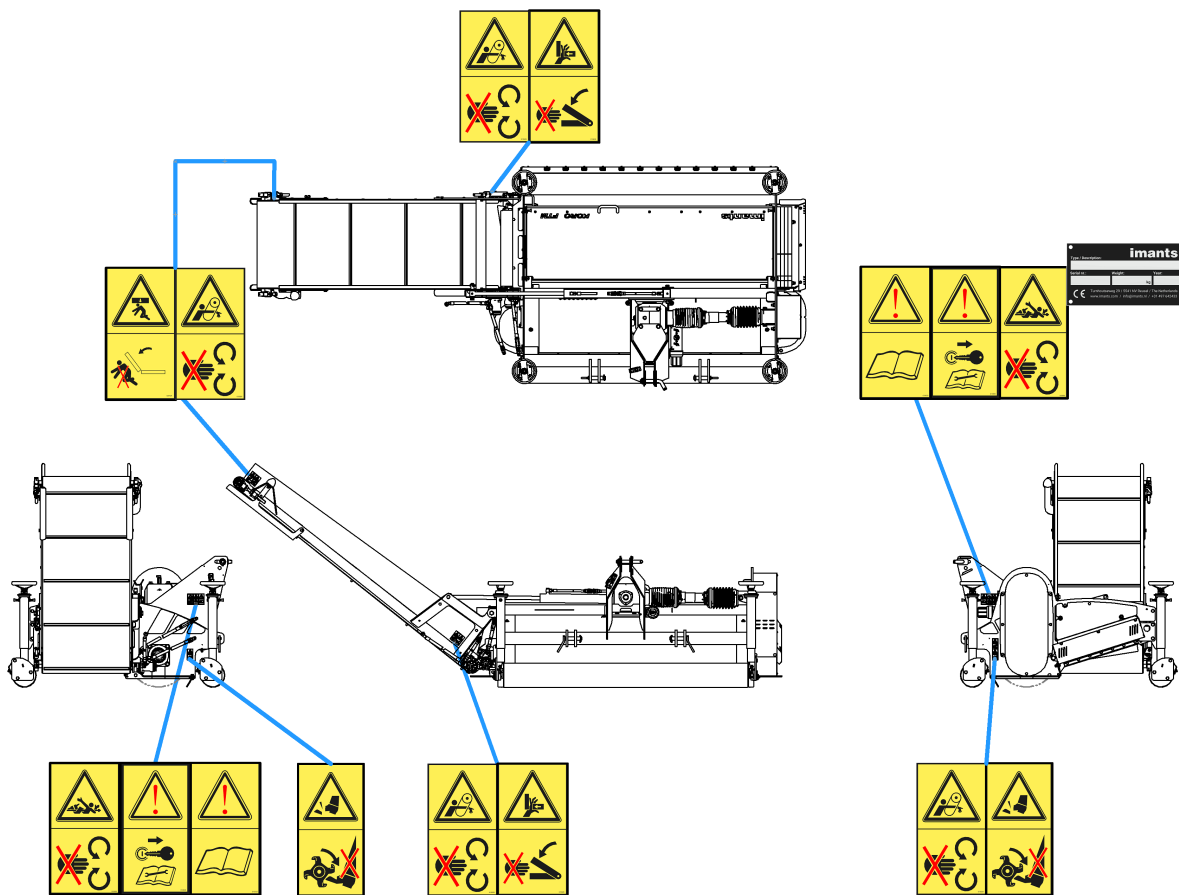

## 2.5 Operator's responsibilities

It is the operator's responsibility to ensure the machine is used safely. If the operator does not obey the safety instructions and rules, serious physical injury and major damage to the machine and the surroundings could be the result.

### The operator must

- always be trained and qualified to operate the machine,
- remain alert and avoid hazardous situations,
- always conduct an inspection before use,
- conduct functional tests,
- check the workplace,
- keep bystanders at a safe distance,
- use the machine only for its intended purpose,
- wear the correct protective equipment and work clothing,
- not work under the influence of medicines, alcohol or drugs,
- be fully aware of the safety and usage rules, and
- know what the local government and official body instructions and rules are.

### 3 Residual risks

---



The people operating the machine are responsible for ensuring the work is carried out safely.

---



Every machine has inherent hazards. It is therefore always recommended to exercise the greatest caution when working.

---

Even if all the safety precautions are taken and the machine is used in accordance with the regulations, there are still residual risks:

#### Residual risks

- Sections of the machine folding out, which may cause an injury.
- Contact with rotating parts of the machine.
- Material being ejected from the machine, which may cause an injury.
- Hinged parts, which may cause body parts being pinched.
- Human errors (e.g. fatigue, mental overload, etc.)

## 4 General description of machine

The machine has been designed for professional use:

- On sports fields and golf courses

The machine is constructed as follows: Some parts are available as an optional extra.









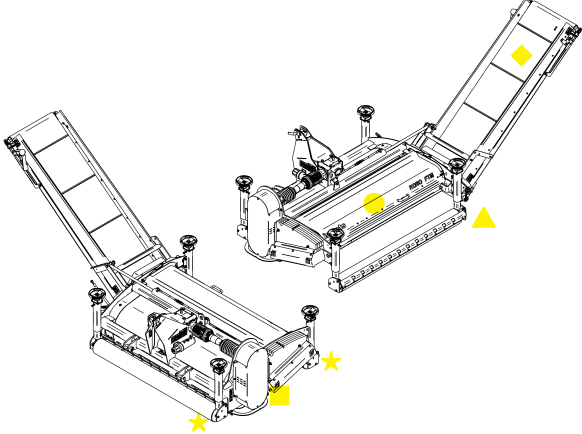
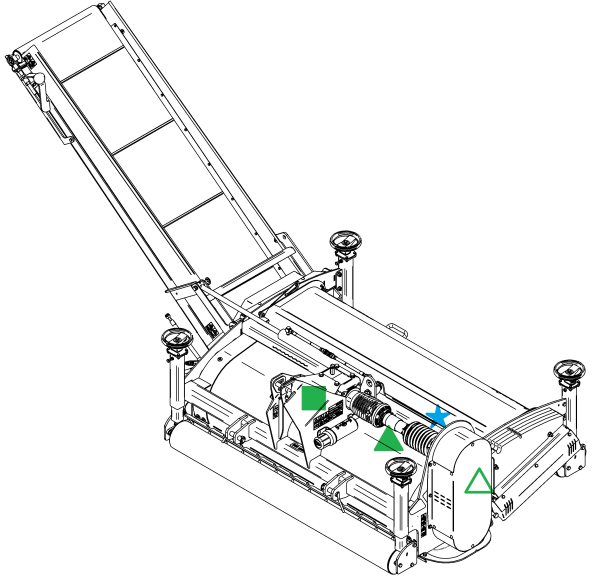

Components	Drive
	
<ul style="list-style-type: none"> <li>•  Centre roller</li> <li>•  Output belts</li> <li>•  Lateral belt</li> <li>•  Feed belt</li> <li>•  Running rollers</li> <li>• </li> <li>• </li> </ul>	<ul style="list-style-type: none"> <li>•  Main gearbox</li> <li>•  PTO shaft drive</li> <li>•  V-belt drive</li> <li>•  Freewheel clutch</li> </ul>

Table 1: Machine parts and drive

Depending on the model, the machine functions are as follows:

- Restoring/maintaining stretches of grass
- Rotovators
- Removing thatch from stretches of grass
- Harvesting stolons of warm season grasses
- Scarifying
- Creating ideal sowing conditions
- Transporting away loosened material

A tractor provides the power needed to drive and tow the machine.

The power of the tractor is transferred to the machine via a: PTO drive shaft

The PTO shaft must rotate at: 540 rpm

The machine is operated from the tractor driver's seat

The tractor's three-point hitch is used to couple up the machine. The machine is fitted with coupling points for a tractor with a lifting hitch of Category 2

## 5 Machine specifications

### 5.1 FTM

		2.0		2.5	
<b>Dimensions</b>					
Working width	[mm] (")	2000	79	2500	98
Machine width (operational)	[mm] (")	4490	177	5400	213
Machine width	[mm] (")	2550	100	3050	120
Machine length	[mm] (")	1770	70	1770	70
Machine height (on legs)	[mm] (")	1115	44	1115	44
<b>Weight</b>					
Machine weight	[kg] (lbs)	1150	2535	1260	2778
Terraplane rotor	[kg] (lbs)	254	560	285	628
Universe-4 rotor	[kg] (lbs)	205	452	250	551
Centre roller	[kg] (lbs)	54	119	-	-
<b>Working speed</b>					
Max. working speed	[km/h] (mph)	3.0	1.9	3.0	1.9
<b>Working depth</b>					
Max. working depth	[mm] (")	35	1.4	35	1.4
<b>Power</b>					
Min. power	[kW(pK)]	44(60)		44(60)	
Max. power	[kW(pK)]	90(122)		90(122)	
<b>PTO drive shaft</b>					
Drive train rotational speed	[/min] (rpm)	540		540	
PTO drive shaft type		W2500		W2500	
<b>Supply lines</b>					
Max. hydraulic pressure	[bar] (psi)	200	2900	200	2900
<b>Noise level</b>					
Noise level	dB(A)	< 80		< 80	

## 6 Loading and unloading the machine



Never go under a hoisted-up machine.



Use only approved lifting equipment (wire ropes, belts, chains, etc.) that:

- have a permissible load that is greater than the weight of the machine, see type plate
- do not have any defects.



Only qualified personnel should hoist machines.



The machine's centre of gravity is indicated by the symbol: ● This is for a standard machine without options

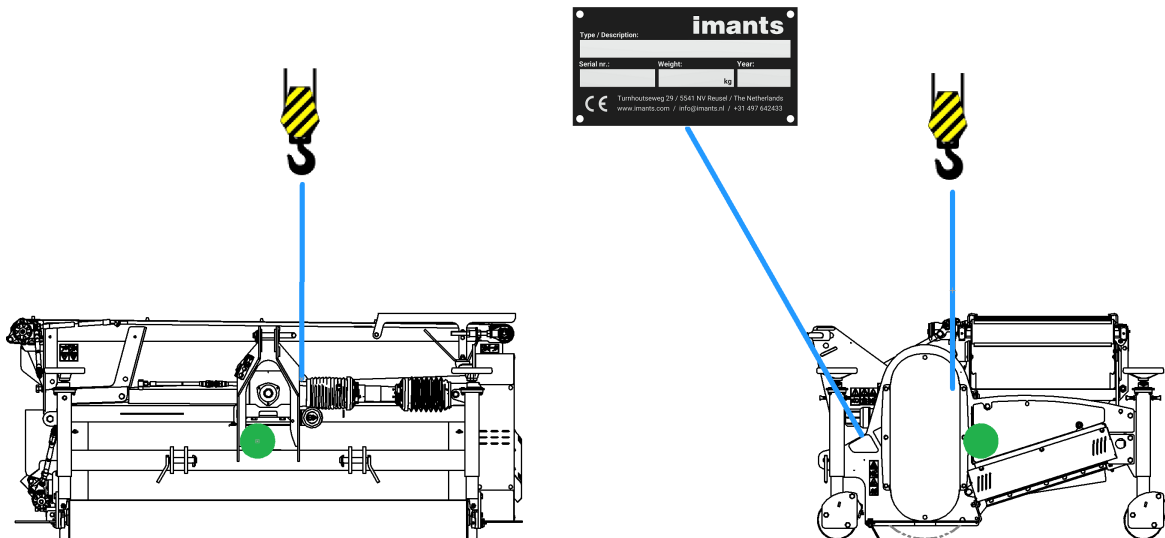

## 7 Putting the machine into operation



The user must have read through the whole contents of this manual and must follow to the letter the instructions therein.



20% of the unladen weight of the tractor must always rest on the front axle.



A PTO drive shaft of the wrong length may cause serious damage to the tractor and the machine. This would invalidate the CE marking of the PTO drive shaft [Putting the PTO shaft into operation](#) on page 23



Connect the overload clutch according to the instructions provided by the manufacturer of the PTO drive shaft.



Check whether the clearance around the PTO drive shaft is sufficient whatever the operating conditions. The PTO drive shaft will become damaged if there is too little clearance.

### Procedure

1. Check:
  - That all bolted connections are tight
  - The oil level in the gearbox(es)
  - The hydraulic system for defects
2. Couple the machine up to the tractor (see section on coupling and uncoupling)
3. Do **not** connect the PTO drive shaft yet
4. Carefully read the manufacturer's instructions for the PTO drive shaft
5. Shorten the PTO drive shaft [Putting the PTO shaft into operation](#) on page 23
6. Connect the PTO shaft to the tractor

## 7.1 Putting the PTO shaft into operation

The PTO shaft is an essential part of the machine.

There are a number of matters that need to be watched out for:

- See PTO drive shaft manual
- or <https://www.walterscheid-group.com/mediaportal/#downloads> Go to tab Walterscheid

### Points of attention

1. The length of the PTO shaft.
  - With the shortest operating distance between the tractor and the machine , the PTO shaft must still be able to slide in by 40 mm / 1.6 inch . In this, account must be taken of:
    - A hydraulic top link (if present) in its shortest position
    - The minimum profile overlap is: See PTO shaft manual
2. Attach overloading/freewheel clutch or bolt connection (conical) at the machine end

## 8 Transport



20% of the unladen weight of the tractor must always rest on the front axle.

The machine may be transported on the public road while on the tractor.

Information concerning local traffic regulations must be obtained in advance.

### **This information could include matters such as:**

- Maximum transport width;
- Maximum axle load;
- Lighting to be shown;
- Use of warning signs.

### **Before the tractor-machine combination goes on a public road at least check the following:**

1. That the top link and draw bar pins are secured with a linch pin
2. That the legs are raised and secured
3. That the lighting works, is undamaged and properly visible
4. That the braking system works properly
5. That the supply lines are correctly connected
6. That the conveyor belts are folded in (and secured)

## 9 Working with the machine

---



The machine may only be used and maintained by persons who are familiar with the machine and have been made aware of the risks. No-one who could not be expected to make correct use of the machine is to be permitted to commission or operate the machine.

---



Before carrying out maintenance work or changing the machine's settings, it must have come to a complete standstill. The tractor's engine must be switched off and the key must have been removed from the ignition.

---



The operating speed must be adjusted to suit the soil and working conditions.

---



The machine is only suitable for treating soil and fields that are free of obstacles, such as stones, tree stumps, steel objects, etc.

---



Risk of crushing during folding and unfolding of the machine.

---



Only engage the PTO if there is nobody in the machine's danger zone.

---



While working with the machine, never depress the clutch pedal, nor take the tractor out of gear. The machine could actually push the tractor forward. This could lead to hazardous situations.

---



It is not permitted to stand on the machine or to stand within the range of the machine while the machine is in use. This also applies during transport.

---



Risk of additional wear of the PTO drive shaft if the shaft angles are unequal.

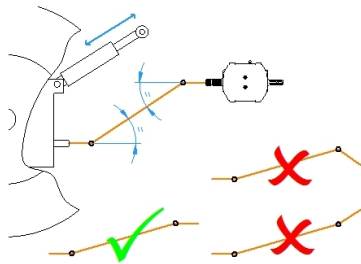

Take into account the permissible angle rotations of the rotating PTO drive shaft.



Limit the lifting height. The sudden excessive lifting of a powered machine can cause serious damage to the:

- PTO
- PTO drive shaft
- gear box



Immediately turn off the PTO if the raised machine runs erratically.

---

## 9.1 Tractor settings



- Ensure there is sufficient weight at the front of the tractor
- Ensure the tyre pressures are equal
- Use the soft start to engage the PTO shaft
- Set the oil output to the right amount [L/min] / (USgal/min)
- Place the lifting arms at the same height.
- Put the lowering speed of the hitch to slow
- Select the correct PTO speed: 540 rpm

## 9.2 Coupling the machine

In order to use the machine it must first be coupled up.









1. Set the tractor lift arms at equal height
2. During all operational activities, make sure the machine cannot roll away unintentionally.
3. Check that the PTO drive shaft slides in and out easily (lubricate!)
4. Send people away from the danger area between the tractor and the machine
5. Drive the tractor close to the machine, leaving about 25 cm of room between the tractor and the machine
6. Secure the tractor to prevent unintended starting or rolling away
7. Connect supply lines: hydraulic, electrical or air
8. Reverse further with the tractor towards the machine
9. Connect the three-point hitch to the machine's coupling points. Ensure the coupling points are properly secured
10. Use the stabilizer rods to secure the tractor's lifting arms
11. Raise the machine so that it is in the transport position. Be aware of the max. lifting height
12. Check that all supply lines are properly connected so that all machine function operate correctly
13. By performing a visual inspection, check that the three-point hitch is properly locked before driving away



## 9.3 Machine settings

### 9.3.1 Counter default setting

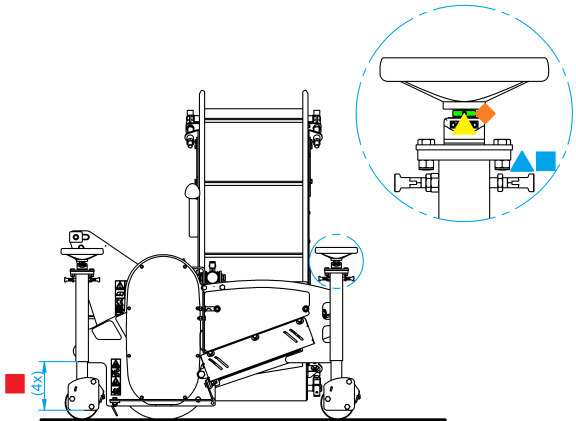

Before carrying out maintenance work or changing the machine's settings, it must have come to a complete standstill. The tractor's engine must be switched off and the key must have been removed from the ignition.

Procedure	Illustration
<ol style="list-style-type: none"> <li>1.  Unscrew the adjustment screws.</li> <li>2.  Unblock the locking mechanism</li> <li>3.  Set the adjustable legs to the indicated distance: See the table below.</li> <li>4.  Use the ring to set the counters to 00000</li> <li>5.  Block the locking mechanism</li> <li>6.  Tighten the adjustment screws.</li> </ol>	

Rotor type	Distance  [mm] / (")
	256 / 10.08
	256 / 10.08



The counters can also be zeroed by placing the machine on a totally flat surface. Rotate the running rollers so that the rotor just touches the ground. Zero the counters. This method can also be used when the blades are slightly worn.

## 9.3.2 Configuring the counters



Before carrying out maintenance work or changing the machine's settings, it must have come to a complete standstill. The tractor's engine must be switched off and the key must have been removed from the ignition.

Procedure	Illustration
<ol style="list-style-type: none"> <li>1. <span style="color: blue;">▲</span> Unblock the locking mechanism</li> <li>2. <span style="color: green;">▲</span> Use the adjusting wheel to set it to the correct depth</li> <li>3. <span style="color: blue;">■</span> Block the locking mechanism</li> </ol>	

The spindles can be used to adjust the height of the running rollers

Procedure	Illustration																		
<ol style="list-style-type: none"> <li>1. Zero the rear roller</li> <li>2. The front roller indicates the working depth</li> </ol>	<table border="1" data-bbox="1201 1070 1410 1249" style="margin-left: auto; margin-right: auto;"> <thead> <tr> <th>A</th> <th>B</th> <th>↓mm</th> </tr> </thead> <tbody> <tr> <td>0005.0</td> <td>0000.0</td> <td>5</td> </tr> <tr> <td>0010.0</td> <td>0000.0</td> <td>10</td> </tr> <tr> <td>0015.0</td> <td>0000.0</td> <td>15</td> </tr> <tr> <td>... .</td> <td>0000.0</td> <td>..</td> </tr> <tr> <td>... .</td> <td>0000.0</td> <td>..</td> </tr> </tbody> </table>	A	B	↓mm	0005.0	0000.0	5	0010.0	0000.0	10	0015.0	0000.0	15	... .	0000.0	..	... .	0000.0	..
A	B	↓mm																	
0005.0	0000.0	5																	
0010.0	0000.0	10																	
0015.0	0000.0	15																	
... .	0000.0	..																	
... .	0000.0	..																	

### 9.3.3 Centre roller



Before carrying out maintenance work or changing the machine's settings, it must have come to a complete standstill. The tractor's engine must be switched off and the key must have been removed from the ignition.

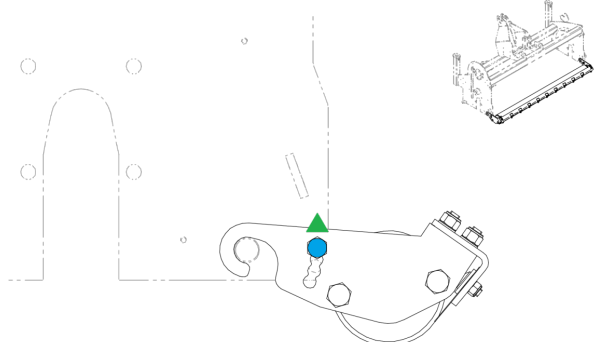

For reasons of quality and safety, only use original **Imants®** parts.

Procedure	Illustration
<ol style="list-style-type: none"><li>1.  The centre roller is secured with a bolt connection</li><li>2. The centre roller can be set to four different heights thanks to the two holes in the side wall and the 4 recesses in the roller's frame. The position depends on the working depth.</li><li>3. Raise the height of the rear running roller.</li></ol>	

### 9.3.4 Ballast



Before carrying out maintenance work or changing the machine's settings, it must have come to a complete standstill. The tractor's engine must be switched off and the key must have been removed from the ignition.



For reasons of quality and safety, only use original **Imants®** parts.

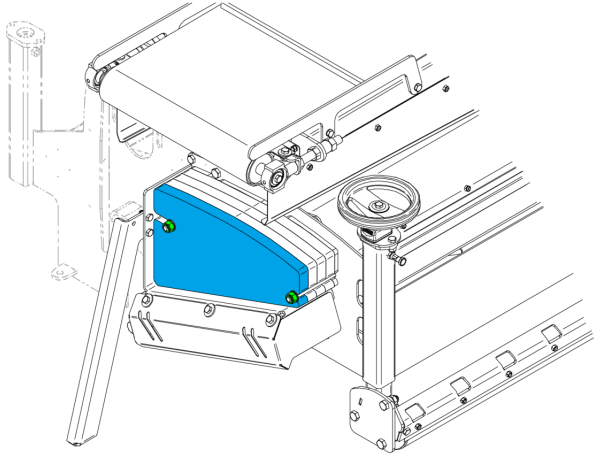

Procedure	Illustration
<p>1. Add/remove ballast plates.</p>	
Weight [kg] / (lbs)	Number
<ul style="list-style-type: none"> <li>• 29.5 / 65</li> </ul>	<ul style="list-style-type: none"> <li>• 4</li> </ul>



Removing the ballast plates makes the machine lighter. However, doing so moves the centre of gravity further away from the middle of the machine.





### 9.3.5 Replacing rotors

Rotor type	FTM	Rotor weight kg (lbs)
	2.0	254 / 560
	2.5	285 / 628
	2.0	205 / 452
	2.5	250 / 551

Table 2: Rotor details

Procedure	Illustration
<ol style="list-style-type: none"> <li>1. Couple the machine to the tractor.</li> <li>2. Unfold the side arm conveyor.</li> <li>3. Do not connect the PTO drive shaft.</li> <li>4. Carefully lower the machine with both running rollers to the ground.</li> <li>5. Adjust both running rollers so that the rotor just touches the ground.</li> </ol>	
<p>Remove:</p> <ol style="list-style-type: none"> <li>1.  V-belt drive guard</li> <li>2.  V-belts</li> <li>3.  Bottom pulley</li> <li>4.  Splash plate The bolts can be reached by opening the cover above the lateral conveyor.</li> <li>5.  The bearing blocks' bolts on both sides</li> </ol>	
<ol style="list-style-type: none"> <li>1. Lift the machine</li> <li>2. The rotor remains on the ground.</li> <li>3. Remove the bearing blocks.</li> </ol>	
<ol style="list-style-type: none"> <li>1. Slide the bearing blocks on to the new rotor's shaft.</li> <li>2. Carefully lower the machine.</li> </ol>	
<p>Install:</p> <ol style="list-style-type: none"> <li>1. The bearing blocks. Rotate the running rollers to align the bearing blocks' hole pattern with the side wall.</li> <li>2. Pulleys (align).</li> <li>3. V-belts.</li> <li>4. Splash plate.</li> <li>5. PTO drive shaft</li> <li>6. Perform a test run.</li> <li>7. V-belt guard.</li> </ol>	

## 9.3.6 Aligning the pulleys

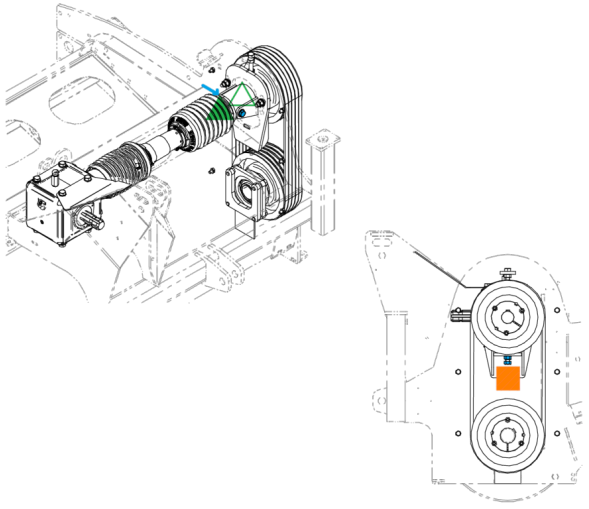
Procedure	Illustration
<ul style="list-style-type: none"><li>•  Slacken bolt connection a few turns</li><li>• Unscrew lock nut</li><li>•  Rotate the adjustment bolt until the pulleys are aligned (use a ruler).</li><li>• Retighten the lock nut.</li><li>•  Tighten bolt connection</li><li>• Bolt connection torque:  M16 (8.8) 210 [Nm] / 155 (lbf ft)</li></ul>	

## 9.4 Starting and stopping work and settings

Working with the machine is described in the two tables below. Actions that recur during every job for starting and stopping are shown **printed in bold**. One-off settings are printed normally. Some of the instructions may concern an optional extra that your machine may not have.



The machine must never be turned on when the driven rotor is placed on the ground. This can result in serious damage to the tractor and the machine.

1.	Check that the correct PTO speed is engaged: 540
2.	Output belt from transport position to working position
3.	Adjust the height of the running rollers <a href="#">Configuring the counters</a> on page 30
4.	Engage output belts
5.	<b>Drive forwards</b>
6.	<b>Slowly lower the machine while it is moving, and the engine is revving slowly.</b>
7.	<b>Engage the PTO just before the rotor contacts the ground</b>
8.	<b>Gradually increase the engine speed and the driving speed.</b>
9.	After 20 metres, check the machine's working depth.
10.	If the working depth is correct, go to next step, otherwise change the working depth <ol style="list-style-type: none"> <li>Readjust height of running rollers <a href="#">Configuring the counters</a> on page 30</li> <li>Recheck working depth. If working depth is correct, continue work or go through this step again</li> </ol>
11.	Ensure the top link is in the centre of the slotted hole

Table 3: Starting the machine and configuring the settings

1.	<b>Reduce the travelling speed</b>
2.	<b>Reduce the engine speed</b>
3.	<b>Raise the machine out of the ground in a smooth motion while the machine is moving.</b>
4.	<b>Disengage the PTO during lifting</b>
5.	After completing the work, put the feed belt into the transport position

Table 4: End of job, stopping the machine (and settings)



The machine's working speed depends on:

- The depth of the tillage
- Type of soil
- Soil condition (wet, dry)
- Compacting (disruptive layers)

\*)= If present \*\*)= Optional

## 9.5 Blocking the machine



Apply the tractor's handbrake so that it cannot roll away.



Work may only be carried out under a raised machine if the machine has been properly supported.



Before carrying out maintenance work or changing the machine's settings, it must have come to a complete standstill. The tractor's engine must be switched off and the key must have been removed from the ignition.



Be aware of residual mechanical, hydraulic, pneumatic and electrical energy present in the machine.

The machine may come to a halt because it is full, or because of stones or other obstacles.

The V-belts slip in the event of overloading.



1. Immediately disengage the PTO drive shaft
2. Raise the machine fully out of the ground.
3. Place the machine on the ground and turn off the tractor engine.
4. Remove the obstacle from the ground or the machine.
5. Start tilling on the newly prepared section of soil.

## 9.6 Uncoupling the machine



Be aware of residual mechanical, hydraulic, pneumatic and electrical energy present in the machine.



1. Let the running rollers down far enough that the rotor does not touch the ground when the machine is put down
2. Place the machine on a flat, stable surface
3. During all operational activities, make sure the machine cannot roll away unintentionally.
4. Secure the tractor to prevent unintended starting or rolling away
5. Disengage the three-point hitch
6. Drive the tractor forward about 25 cm
7. Disconnect supply lines: hydraulic, electrical or air

## 10 Maintenance of the machine



The machine may only be used and maintained by persons who are familiar with the machine and have been made aware of the risks. No-one who could not be expected to make correct use of the machine is to be permitted to commission or operate the machine.

---



Before carrying out maintenance work or changing the machine's settings, it must have come to a complete standstill. The tractor's engine must be switched off and the key must have been removed from the ignition.

---



Never use your hand or fingers to try to stop a leak in the hydraulic system. Fluid escaping under pressure (hydraulic oil) could enter the body through the skin and cause serious injury. Consult a doctor immediately in case of wounds from hydraulic oil!

---



Avoid dangerous situations. Repair broken or worn parts before using the machine.

---



Be aware of residual mechanical, hydraulic, pneumatic and electrical energy present in the machine.

---



Work may only be carried out under a raised machine if the machine has been properly supported.

---



For reasons of quality and safety, only use original **Imants®** parts.

---

## 10.1 Daily inspection

	
<p><b>General</b></p> <ul style="list-style-type: none"> <li>• Warning stickers</li> <li>• Loose bolted connections</li> <li>• Conveyor belts</li> </ul>	<p><b>Guards</b></p> <ul style="list-style-type: none"> <li>• Rotor area guard</li> <li>• PTO drive shaft guard(s)</li> <li>• V-belt drive guard(s)</li> </ul>
<p><b>Wear parts</b></p> <ul style="list-style-type: none"> <li>• TerraPlane® chisel</li> <li>• Universe® digging blade</li> </ul>	<p><b>Drive</b></p> <ul style="list-style-type: none"> <li>• Oil level in gearbox(es)</li> <li>• V-belt tensioner(s)</li> <li>• Vent nipples</li> </ul>

## 10.2 Drive train

The drive train comprises the following components:

### 10.2.1 PTO drive shaft



Keep the PTO drive shaft clean. Lubricate sliding parts so that the PTO drive shaft can slide in and out easily.

---

- Consult the PTO shaft manual for its maintenance
- of <http://www.gkn-walterscheid.de/downloads/anleitungen>

## 10.2.2 Gear box



The gearbox is filled with running-in oil. This should be changed after **50** operating hours. See oil type in table below



Position indications on the machine are always expressed as seen from the rear of the machine.



Dispose of the waste oil in an environmentally responsible manner. To do so, follow the local statutory regulations in force



### Check the oil level

1. Set the gear box to be horizontal
2. The oil level must be in the middle of the sight glass of the level plug
3. The oil level should be at the bottom of the level plug



### Change the oil

1. Place a collection pan under the gear box
2. Check the vent plug for correct operation
3. Open the drain plug
4. Drain all the oil
5. Screw the drain plug back in and fill the gearbox
6. Screw the vent and filler plugs back in

### 10.2.2.1 Middle gearbox

Symbol	Description	Gearbox type
●	Vent plug / filler plug	
▲	Level plug	
■	Drain plug	

Table 5: Oil level legend 9014-G175

Gearbox type	Oil type	Oil volume	Maintenance interval
031370: 9014-G175	MobilGear 600XP320	2.3 [L] / 0.6 (USgal)	12 months or 500 operating hours

Table 6: Gearbox filling details and maintenance interval 9014-G175

## 10.2.3 Tensioning the V-belt



Procedure	Illustration
<ol style="list-style-type: none"> <li>1. Disassemble the protective cover</li> <li>2.  Slacken bolt connection a few turns</li> <li>3. The V-belt pulleys should not have to be aligned. They are aligned during manufacture. However, if they do have to be aligned, see: <a href="#">Aligning the pulleys</a> on page 34</li> <li>4. Tighten the lock nuts.</li> <li>5. Bolt connection torque:</li> <li>6. Fit the guard.</li> </ol> <p> M16 (8.8) 210 [Nm] / 155 (lbf ft)</p>	

Table 7: Tensioning the V-belt

Procedure	Illustration
<p>New V-belt</p> <ol style="list-style-type: none"> <li>1. Set dimension A to 8 mm</li> <li>2. Place this side of the measurement tool in the middle of the V-belt.</li> <li>3. Press the black cap.</li> <li>4. After the black cap has been pressed, ring A must be at the same height as another V-belt.</li> <li>5. Ring B must indicate 7.5 kg.</li> </ol> <p>Used V-belt</p> <ol style="list-style-type: none"> <li>1. Set dimension A to 11 mm</li> <li>2. Place this side of the measurement tool in the middle of the V-belt.</li> <li>3. Press the black cap.</li> <li>4. After the black cap has been pressed, ring A must be at the same height as another V-belt.</li> <li>5. Ring B must indicate 7.5 kg.</li> </ol>	

Table 8: V-belt adjustment measurement tool

## 10.3 Periodic maintenance and inspection: Checking the vent nipples

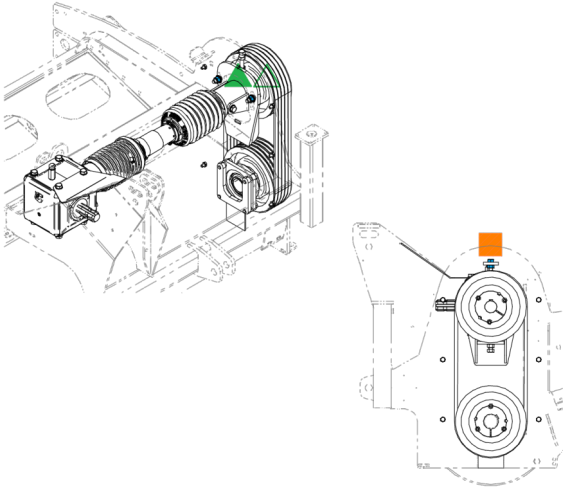
Symbol	Number of bleed nipples	Maintenance interval
★	1 ( Main gearbox )	12 months or 500 operating hours

Table 9: Checking the vent nipples

## 10.4 Installing the clamping bush



Procedure		Illustration	
<ol style="list-style-type: none"> <li>1. Clean the following surfaces before installing the clamping bush.               <ol style="list-style-type: none"> <li>a. Bore/hole</li> <li>b. Tapered clamping bush</li> <li>c. Tapered ring</li> <li>d. Shaft (pay attention to any burrs)</li> </ol> </li> <li>2. Position the clamping bush in the pulley in such a way that all the holes are aligned. Note: half-threaded holes must be opposite unthreaded holes!</li> <li>3. First tighten the adjustment bolts  by hand, but do not fully tighten them.</li> <li>4. If a spline is used, begin by placing it in the slot, then place the pulley at the correct distance on the shaft.</li> <li>5. Now, tighten the adjustment bolts  alternately to the <b>correct torque</b>.</li> <li>6. After the machine has run for 30-60 minutes, check the torque again.</li> </ol>	<b>Type</b>	<b>Tightening torque [Nm] / (lbf ft)</b>	
	1008	6 / 4.5	
	1108	6 / 4.5	
	1210	20 / 15	
	1215	20 / 15	
	1310	20 / 15	
	1315	20 / 15	
	1610	20 / 15	
	1615	20 / 15	
	2012	30 / 22	
	2517	50 / 37	
	3020	90 / 67	
	3030	90 / 67	
			

Table 10: Installing

Procedure		Illustration	
<ol style="list-style-type: none"> <li>1. Unscrew the adjustment screws and remove them.</li> <li>2. Next, put one adjustment screw in the blind hole </li> <li>3. Turn this adjustment screw evenly until the bush comes loose.</li> <li>4. Both the bush and pulley are now loose and can be removed from the shaft.</li> </ol>			

Table 11: Removing

## 10.5 Conveyor belts

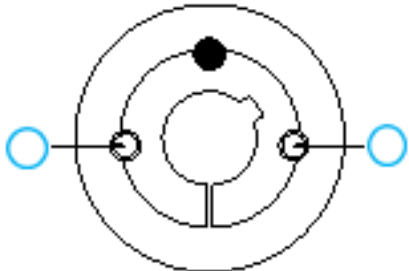

Before carrying out maintenance work or changing the machine's settings, it must have come to a complete standstill. The tractor's engine must be switched off and the key must have been removed from the ignition.

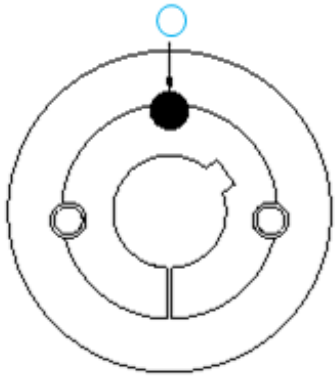

Do not leave the machine in the sun after use. This shortens the service life of the transport belts.

### 10.5.1 Tensioning: general information

Procedure	Illustration
<ol style="list-style-type: none"><li>1. Draw two lines on the slack conveyor belt a distance of 1,000 mm apart</li><li>2. Tension the conveyor belt.</li><li>3. The conveyor belt is correctly tensioned when the lines are 1,005 mm apart</li></ol>	<p>The illustration shows three stages of the tensioning process. Stage 1 shows a slack conveyor belt with a red 'X' in the center. Stage 2 shows the belt with two vertical lines drawn on it, 1000 mm apart, with a pencil icon. Stage 3 shows the belt tensioned, with the distance between the lines now 1005 mm, marked with a green checkmark and a wrench icon.</p>

Table 12: Tensioning the conveyor belts: general information

## 10.5.2 Tensioning the supply conveyor

Procedure	Illustration
<ol style="list-style-type: none"> <li>1. <span style="color: orange;">■</span> Make sure the transport conveyor remains in the middle of the drive roller on the drive side.</li> <li>2. <span style="color: orange;">▲</span> Unscrew the nuts on both sides.</li> <li>3. <span style="color: orange;">●</span> Use both nuts to evenly tension the tensioning roller. The drive roller and the tensioning roller must be parallel to each other.</li> <li>4. <span style="color: orange;">▲</span> Tighten the nuts on both sides.</li> <li>5. After tensioning, run the transport conveyor at a low rotational speed.</li> <li>6. Check whether the transport conveyor continues to run in the middle.</li> <li>7. If not, align it.</li> </ol>	

Table 13: Tensioning the supply conveyor

## 10.5.3 Tensioning the lateral conveyor

Procedure	Illustration
<ol style="list-style-type: none"> <li>1. <span style="color: orange;">■</span> Make sure the transport conveyor remains in the middle of the drive roller on the drive side.</li> <li>2. Remove the cover on the left-hand side.</li> <li>3. <span style="color: orange;">▲</span> Unscrew the nuts on both sides.</li> <li>4. <span style="color: orange;">●</span> Use both nuts to evenly tension the tensioning roller. The drive roller and the tensioning roller must be parallel to each other.</li> <li>5. <span style="color: orange;">▲</span> Tighten the nuts on both sides.</li> <li>6. After tensioning, run the transport conveyor at a low rotational speed.</li> <li>7. Check whether the transport conveyor continues to run in the middle.</li> <li>8. If not, align it.</li> <li>9. Fit the cover.</li> </ol>	

Table 14: Tensioning the lateral conveyor

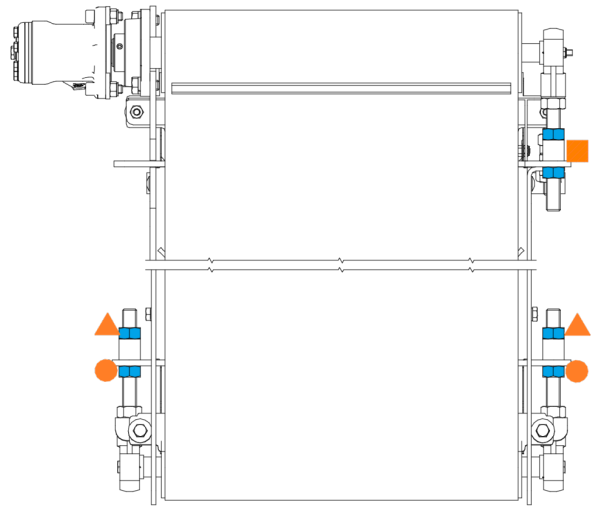
## 10.5.4 Replacing the supply conveyor

Procedure	Illustration
<ol style="list-style-type: none"> <li>1. Fold up the supply conveyor.</li> <li>2. ▲ Slacken the tensioning roller.</li> <li>3. ● Remove the protective cover and the bracket.</li> <li>4. ■ Remove this bracket last and support the supply conveyor.</li> <li>5. Disassemble the transport conveyor.</li> <li>6. Fit a new conveyor belt.</li> <li>7. ■ Fit the bracket.</li> <li>8. ● Fit the protective cover and the bracket.</li> <li>9. ▲ Tension the tensioning roller.</li> </ol>	

Table 15: Replacing the supply conveyor

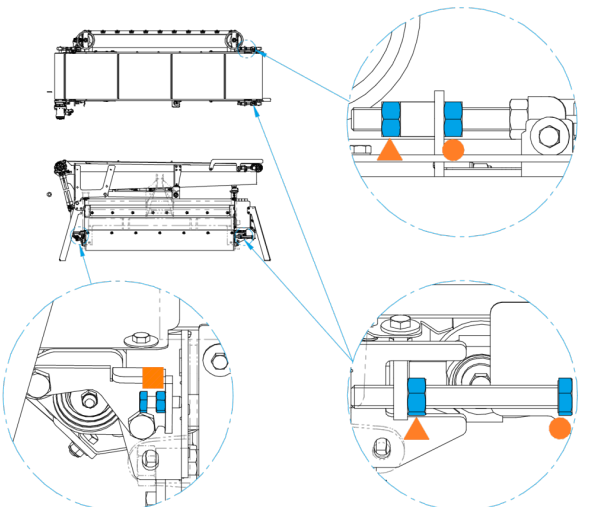
## 10.5.5 Replacing the lateral conveyor

Procedure	Illustration
<ol style="list-style-type: none"> <li>1. Hang the machine in the tractor's hitch.</li> <li>2. ● Place the output belt perpendicularly and secure it in place.</li> <li>3. ■ Open the guard.</li> <li>4. ◆ Disassemble the rear running roller.</li> <li>5. ● Disassemble the conveyor scrapers, protective covers and plates.</li> <li>6. ▲ Slacken the tensioning roller.</li> <li>7. Disassemble the transport conveyor.</li> <li>8. Fit a new conveyor belt.</li> <li>9. ▲ Tension the tensioning roller.</li> <li>10. ● Fit the scrapers, protective covers and sealing plates.</li> <li>11. ◆ Fit the rear running roller.</li> </ol>	

Table 16: Replacing the lateral conveyor

## 10.5.6 Configuring the supply conveyor scrapers

Procedure	Illustration
<ul style="list-style-type: none"> <li>• <span style="color: green;">▲</span> <span style="color: green;">■</span> The drive roller's scraper can be moved using the elongated holes.</li> <li>• <span style="color: green;">◆</span> The conveyor scraper on the inside is suspended so that it swings.</li> </ul>	

Table 17: Supply conveyor scrapers

## 10.5.7 Configuring the lateral conveyor scrapers

Procedure	Illustration
<ol style="list-style-type: none"> <li>1. <span style="color: green;">▲</span> <span style="color: green;">■</span> The drive roller's scraper can be moved using the elongated holes.</li> <li>2. <span style="color: green;">●</span> The plastic conveyor scrapers on the outside can be moved using the elongated holes.</li> <li>3. <span style="color: green;">◆</span> The conveyor scraper on the inside is suspended so that it swings.</li> </ol>	

Table 18: Lateral conveyor scrapers

## 10.6 Wear parts

### 10.6.1 Replace Universe<sup>®</sup> digging blade



Before carrying out maintenance work or changing the machine's settings, it must have come to a complete standstill. The tractor's engine must be switched off and the key must have been removed from the ignition.



For reasons of quality and safety, only use original **Imants<sup>®</sup>** parts.



Dispose of any worn components in an environmentally responsible manner. Always follow the locally applicable statutory regulations.



Procedure	Illustration
<ol style="list-style-type: none"> <li>1. ▲ Remove bolt connection</li> <li>2. Remove Universe<sup>®</sup> digging blade</li> <li>3. Clean wear and tear part holder</li> <li>4. Install Universe<sup>®</sup> digging blade</li> <li>5. ▲ Fit bolt connection</li> <li>6. Bolt connection torque: ▲ M10x1.25 (12.9) Moer KI-8 51 [Nm] / 38 (lbf ft)</li> </ol> <p>● Four blades on the outside of the rotor have a protective plate fitted in front of the holder.</p>	

Table 19: Universe<sup>®</sup> digging blade

## 10.6.2 Replace TerraPlane® chisel



Before carrying out maintenance work or changing the machine's settings, it must have come to a complete standstill. The tractor's engine must be switched off and the key must have been removed from the ignition.



For reasons of quality and safety, only use original **Imants®** parts.



Dispose of any worn components in an environmentally responsible manner. Always follow the locally applicable statutory regulations.



Procedure	Illustration
<ol style="list-style-type: none"> <li>1.     ▲ Remove bolt connection</li> <li>2.     Remove TerraPlane® chisel</li> <li>3.     Clean wear and tear part holder</li> <li>4.     Install TerraPlane® chisel</li> <li>5.     ▲ Fit bolt connection</li> <li>6.     Bolt connection torque: ▲ M12 (8.8) 86 [Nm] / 64 (lbf ft)</li> </ol>	

Table 20: TerraPlane® chisel

# 11 Cleaning



Never clean a machine while it is in operation. There is a risk of serious injury or even death.

---



Carefully check hydraulic hoses and electrical cables.

---



Never treat hydraulic hoses and electric cables with gasoline, benzene, petroleum or mineral oils.

---



Lubricate the machine after cleaning it. Especially after the machine has been cleaned using a high-pressure cleaner/steamer or fat-soluble agents.

---



Observe the legal requirements concerning the use and disposal of cleaning agents.

---

When cleaning with a high-pressure cleaner, you must always follow the instructions below:

1. Maximum permitted pressure is 100 bar.
2. The maximum temperature is 50°C
3. Do not clean the electrical components.
4. Never direct the jet of the high-pressure cleaner or steamer directly at the stickers, lubricating points or bearings.
5. Keep the high-pressure cleaner/steamer a minimum distance of 600 mm away from the machine
6. Observe the safety regulations for the use of high-pressure cleaners.

## 12 Decommissioning

When the machine is decommissioned, the parts can be sorted as follows:

1. Metals
2. Plastics
3. Oils and greases



Dispose of the sorted materials in an environmentally responsible manner. Always follow the locally applicable statutory regulations.

# 13 Warranty

## IMANTS BV warranty information

### (A) Warranty

IMANTS BV guarantees that none of the products that it manufactures has any material faults and IMANTS BV issues a warranty for the manufactured products at the time of shipment, which is valid for a period of twelve (12) months from the date of delivery to the customer. IMANTS BV delivers replacement parts, free of charge, for all parts that IMANTS BV considers to be faulty at the time of shipment. Alternatively, IMANTS BV can opt to repair such components or have such components repaired on its behalf on the condition that such components are returned on request to the factory at Turnhoutseweg 29, 5541 NV, Reusel, the Netherlands. The transport costs for the return shipment must be paid in advance.

This warranty does not apply to any products that have been subject to incorrect use, incorrect application, negligence (including, but not limited to, incorrect maintenance), an accident, incorrect installation, a modification (including, but not limited to, the use of components or add-on components for which permission has not been granted), an alteration or repair. Motors and all accessories that are delivered with products from IMANTS BV but which are not manufactured by IMANTS BV are not covered by the warranty issued by IMANTS BV. They are only sold with the explicit warranty, if there is one, issued by the manufacturer concerned. THE ABOVE REPLACES ALL OTHER WARRANTIES, EITHER EXPLICITLY OR IMPLICITLY (INCLUDING GUARANTEES OF SALEABILITY AND SUITABILITY OF ANY PRODUCT FOR A CERTAIN PURPOSE), AS WELL AS ANY OTHER LIABILITY OF IMANTS BV.

### (B) Limitation of liability

It is expressly stated that the liability of IMANTS BV for its products, either on account of termination of the warranty, negligence, strict liability or otherwise, is limited to the delivery of replacement components and that IMANTS BV is not liable for any injury, loss, damage or expenses, neither directly or indirectly, including, but not limited to, a loss of use, income, profit or production, or higher operational costs, or decay or damage of materials resulting from the sale, installation, use, inability to use, or repair or replacement of IMANTS BV products.

Every operation that is expressly forbidden in the operating instructions or instruction manuals that are provided with the machine, and any alteration or assembly procedure that is not recommended by or is not permitted according to the operating or maintenance instructions invalidates such warranty.

### (C) Registration

THIS WARRANTY IS INVALID UNLESS THE REGISTRATION FORM IS COMPLETEED AND RETURNED TO THE FACTORY AT TURNHOUTSEWEG 29, 5541 NV, REUSEL, THE NETHERLANDS, WITHIN 30 DAYS AFTER DELIVERY OF THE UNIT TO THE CUSTOMER.

No component must be returned under warranty unless IMANTS BV has given permission for it to be returned (RGA - Return Goods Authorization).

ALWAYS STATE THE NAME OF THE COMPONENT, THE COMPONENT NUMBER AND THE SERIAL NUMBER OF THE MACHINE WHEN ORDERING COMPONENTS.

#### NOTE:

IMANTS BV maintains the right to make changes to the design and construction without the obligation to also make these changes to previously sold products. In the event of conflicts, the general terms and conditions of delivery and payment laid down by the Koninklijke Metaalunie are applicable.

## 14 Appendix/Appendices

In this part of the manual, you can find extra information about your machine

## 15 CE declaration

# 16 Notitieblad/Note sheet/Notizenblatt

	<b>Door:</b>	<b>Blad:</b>
	<b>Onderwerp:</b>	<b>Datum:</b>

A large grid of 24 columns and 30 rows for taking notes.																							
--	--	--	--	--	--	--	--	--	--	--	--	--	--	--	--	--	--	--	--	--	--	--	--



# 18 Notitieblad/Note sheet/Notizenblatt

	<b>Door:</b>	<b>Blad:</b>
	<b>Onderwerp:</b>	<b>Datum:</b>

A large grid of 24 columns and 30 rows for taking notes.																							
--	--	--	--	--	--	--	--	--	--	--	--	--	--	--	--	--	--	--	--	--	--	--	--



Imants® BV  
Turnhoutseweg 29  
5541 NV Reusel  
+31 (0)497 642 433  
+31 (0)497 643 205  
[www.imants.nl](http://www.imants.nl)  
[info@imants.nl](mailto:info@imants.nl)